

HP Archive

This vintage Hewlett Packard document was
preserved and distributed by

[www. hparchive.com](http://www.hparchive.com)

Please visit us on the web !

Scanned by on-line curator: Tony Gerbic

**** For FREE Distribution Only *****



HEWLETT-PACKARD COMPANY / OPERATING AND SERVICE MANUAL

202A

LOW FREQUENCY FUNCTION GENERATOR



OPERATING AND SERVICE MANUAL

MODEL 202A

SERIALS PREFIXED: 037 -

LOW FREQUENCY
FUNCTION GENERATOR

Copyright HEWLETT-PACKARD COMPANY 1959
1501 PAGE MILL ROAD, PALO ALTO, CALIFORNIA, U. S. A.



TABLE OF CONTENTS

Section	Page	Section	Page
I GENERAL INFORMATION	1-1	IV MAINTENANCE (cont'd)	
1-1. General	1-1	4-3. Function Generator (bi-stable circuit and integrator)	4-2
II OPERATING INSTRUCTIONS	2-1	4-4. Sine Synthesizer and Function Selector	4-2
2-1. Inspection	2-1	4-5. Output Amplifier	4-3
2-2. Controls and Terminals.	2-1	4-6. Sync Out.	4-3
2-3. 230-Volt Operation	2-1	4-7. Tube Replacement.	4-3
2-4. Operation	2-1	4-8. Tube Replacement Chart	4-4
2-5. Single-Ended Output	2-2	4-9. Power Supply Regulator Adjustment.	4-4
2-6. Balanced Output.	2-2	4-10. Theory of DC Balance and Distortion Adjustments	4-5
2-7. Sync. Out	2-2	4-11. DC Balance and Distortion Adjustments	4-5
III PRINCIPLES OF OPERATION	3-1	4-12. Adjust Squarewave Amplitude	4-8
3-1. General	3-1	4-13. Frequency Ratio and Calibration Procedure	4-8
3-2. Bi-Stable Circuit	3-2	4-14. Replacement of R58 Potentiometer	4-8
3-3. Linear Integrator.	3-3	4-15. Performance Check.	4-8
3-4. Sine Synthesizer and Function Selector Switch.	3-4	4-16. Output Voltage and Waveform Check	4-8
3-5. Output System	3-6	4-17. Sync Pulse Check	4-10
3-6. Sync Pulse Output	3-7	4-18. Sine Wave Distortion Check	4-10
3-7. Power Supply	3-8	4-19. Dial Accuracy Check	4-10
IV. MAINTENANCE	4-1	V TABLE OF REPLACEABLE PARTS	5-1
4-1. General	4-1	5-1. Table of Replaceable Parts	5-2
4-2. Power Supply	4-1		

LIST OF ILLUSTRATIONS

Figure	Page	Figure	Page
1-1. Model 202A Low Frequency Function Generator.	1-0	4-1. Minimum Distortion and Frequency Adjustment Instrumentation.	4-6
2-1. Single-Ended Output Connections	2-2	4-2. Effect of Triangle Maladjustment on Distortion and Frequency	4-7
2-2. Balanced Output Connections	2-2	4-3. Patterns Showing the Adjustments of R49, R51, R60 and R119 to Obtain Minimum Distortion and Correct Frequency	4-9
3-1. Model 202A Function Generator	3-1	4-4. Output Voltage and Sync Pulse Test Setup.	4-10
3-2. Details of Bi-Stable Circuit and Switching System.	3-2	4-5. Sine Wave Distortion Test Setup	4-10
3-3. Generalized Miller or Feedback Integrator	3-3	4-6. Dial Accuracy Test Setup	4-10
3-4. Simplified Linear Integrator	3-4	4-7. Model 202A Top View Cover Removed	4-12
3-5. Sine Synthesizer and Function Selector.	3-5	4-8. Model 202A Bottom View Bottom Plate Removed	4-13
3-6. 50 μ Waveforms	3-5	4-9. Function Generator and Amplifier	4-14
3-7. Output Amplifier System of Model 202A	3-6	4-10. Power Supply	4-15
3-8. Sync Output Circuit of Model 202A	3-7		
3-9. Model 202A Power Supply.	3-7		



Figure 1-1. Model 202A. Low Frequency Function Generator

Table 1-1. Specifications

<p>FREQUENCY RANGE: 0.008 to 1200 cps in five decade ranges with wide overlap at each dial extreme</p>	<p>MAXIMUM OUTPUT VOLTAGE: At least 30 volts peak-to-peak across rated load (4000 ohms) for all three waveforms. (10.6 volts rms for sine wave)</p>
<p>DIAL ACCURACY: Within $\pm 2\%$ from "1.2" to "12" on dial; $\pm 3\%$ from ".8" to "1.2"</p>	<p>FREQUENCY RESPONSE: Constant within ± 0.2 db over entire frequency range at rated output and load</p>
<p>FREQUENCY STABILITY: Within $\pm 1\%$ including warm-up drift and line voltage variations of $\pm 10\%$</p>	<p>INTERNAL IMPEDANCE: Approximately 40 ohms over the entire range</p>
<p>OUTPUT WAVEFORMS: Sinusoidal, square, and triangular. Selected by panel switch</p>	<p>SINE WAVE DISTORTION: Less than 1% on all ranges except X100. Less than 2% rms on X100.</p>

SECTION I GENERAL INFORMATION

1-1 GENERAL

The Model 202A Low Frequency Function Generator is a compact, convenient, and versatile source of transient-free test voltages between .008 and 1200 cycles per second. It is useful for any general purpose low frequency testing application and is particularly valuable in the testing of servo systems, geophysical equipment, vibration and stability characteristics of mechanical systems, electro-medical equipment, and for the electrical simulation of mechanical phenomena. Three types of output waveform are available; sine, square and triangular. Also, a sync output pulse is available for external use.

The Model 202A Low Frequency Function Generator contains a type of relaxation oscillator that is particularly advantageous for the generation of very low frequencies. Both a triangular and a squarewave voltage function of time are inherent in the oscillating system. Also, a sinewave function is produced by synthesis from the triangular wave.

Output amplitude and distortion are virtually independent of the frequency of operation. This type

of oscillating system is inherently a constant amplitude device so that no A. V. C. system, with associated delay in stabilization after frequency changes, is required.

The frequency range from .008 to 1200 cycles per second is covered in 5 bands. The frequency dial is linear.

The output system is a direct-coupled amplifier system designed for either single ended or balanced output. It has good stability with respect to direct current in the output and very low hum level. Both the FUNCTION selectro switch and the AMPLITUDE control are so arranged that the characteristics of the amplifier are independent of their position. The internal impedance of the output amplifier is approximately 40 ohms, and the unit is rated to deliver at least 30 volts peak-to-peak to a 4000 ohm load.

A negative peak sync pulse of 10 volts into a 2500 ohm load is also provided. It has a duration of less than 5 microseconds and occurs at the crest of the sinewave and at corresponding positions with the other functions.

Table 1-1. Specifications (Cont'd)

OUTPUT SYSTEM:

Can be operated either balanced or single-ended. Output system is direct-coupled; dc level of output voltage remains stable over long periods of time.

HUM LEVEL:

Less than 0.5% at rated output.

SYNC PULSE

10 volts peak negative, less than 5 microseconds duration. Sync pulse occurs at crest of sine wave and with corresponding positions on other waveforms.

WEIGHT:

Cabinet Mount: Net 42 lbs
Rack Mount: Net 37 lbs

POWER:

115 or 230 volts $\pm 10\%$, 50 to 1000 cps, 150 watt

DIMENSIONS: Cabinet Mount: 20-3/4 in. wide, 12-3/4 in. high, 14-5/8 in. deep.

Rack Mount:

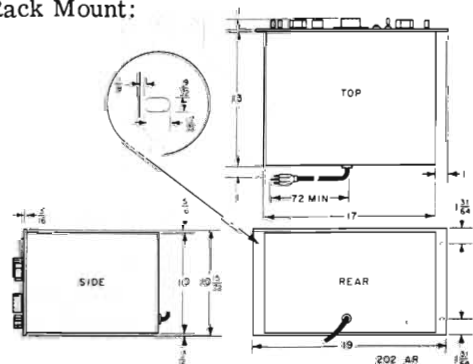

SECTION II

OPERATING INSTRUCTIONS

2-1 INSPECTION

After the instrument is unpacked, the instrument should be carefully inspected for damage received in transit. If any shipping damage is found, follow the procedure outlined in the "Claim for Damage in Shipment" page at the back of the instruction book.

2-2 CONTROLS AND TERMINALS

RANGE

This switch is used to select the desired frequency range to be covered by the frequency dial.

FUNCTION

This switch is used to select any one of the three types of output waveform.

FREQUENCY

This dial is calibrated directly in cycles per second for the X1 frequency range of the oscillator. The knob just below the dial escutcheon is directly connected to the frequency varying element. The lower knob is a mechanical vernier for fine adjustment of the frequency.

AMPLITUDE

This control adjusts the amplitude of the oscillator voltage admitted to the amplifier and, therefore, the output of the instrument. This control is calibrated from 0 to 100 in arbitrary units.

POWER

This toggle switch controls the power supplied to the instrument from the power line.

FUSE

The fuseholder, which is located on the panel, contains the power line fuse. Refer to the Table of Replaceable Parts for the correct fuse rating.

OUTPUT

This group consists of three terminals. The one marked "G" is connected directly to the instrument chassis. The other two terminals, vertically aligned, are the OUTPUT terminals. With respect to the ground terminal each of these outputs has equal magnitude of signal, but they are 180° out of phase with each other. The internal impedance between the two OUTPUT terminals is approximately 40 ohms.

SYNC OUT

The Sync Out terminals are single-ended and have an internal impedance of about 2,000 ohms.

Power Cable

The three-conductor power cable is supplied with a three-prong plug. The third prong is a round off-set pin which provides a chassis ground. An adapter may be obtained to permit use of this plug with two-conductor receptacles.

2-3 230-VOLT OPERATION

This instrument is shipped from the factory with the power transformer primaries connected in parallel for 115 v operation, unless otherwise specified on the order. If 230 v operation is desired, the primaries will have to be connected in series as shown in "Transformer Details" on the schematic wiring diagram of the Power Supply Section.

2-4 OPERATION

The following step-by-step procedure should be used as a guide when operating this instrument.

- 1) Turn the POWER switch to ON. Allow thirty seconds for oscillations to start. The instrument will operate nearly within specifications after a few minutes warm-up. It will be within specifications after 30 minutes.

2) Set the RANGE and FREQUENCY controls for the desired frequency. The frequency dial scale must be multiplied by the multiplying factor indicated by the RANGE switch setting to obtain the oscillator frequency. Example: 4 (on dial scale) x .1 (multiplying factor indicated by RANGE switch setting) = .4 cycles/sec.

3) Set the FUNCTION switch for the desired output waveform.

4) Connect the equipment under test to the OUTPUT terminals.

5) Adjust the AMPLITUDE Control for the desired output voltage. Because the frequency response is rated ± 0.2 db, the output amplitude may be measured at any convenient frequency and the output level will be correct (within these limits) for any other frequency.

NOTES

When small output voltages are required it may be desirable to use an external attenuator. This is because the hum and noise in the output is nearly constant with output amplitude.

To minimize distortion in the output waveform, always use the lowest RANGE when the overlap of the FREQUENCY dial permits a choice.

2-5 SINGLE-ENDED OUTPUT

The terminal marked "G" is isolated from the actual OUTPUT terminals. For single-ended operation "G"

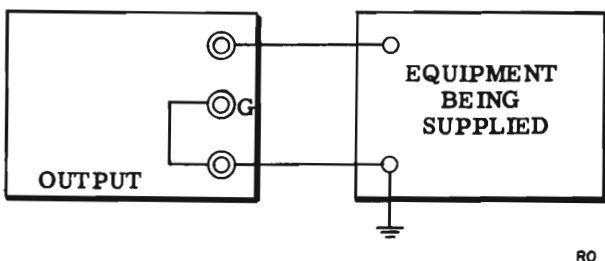

Figure 2-1. Single-Ended Output Connections

must be connected to one of the OUTPUT terminals, and the strapped pair will then be the ground side of the output.

2-6 BALANCED OUTPUT

Connect the two OUTPUT binding posts to the equipment being supplied. The "G" binding post may then be connected to the chassis of the equipment being driven. Under these conditions the internal impedance of the Model 202A from either OUTPUT terminal to ground is 7900 ohms in series with a $1 \mu f$ capacitor (C29). A maximum dc voltage of 400 volts may be applied between either OUTPUT terminal and the "G" terminal without damaging the $1 \mu f$ capacitor (C29). The 40 ohms internal impedance (resistive) will shunt the impedance existing between the two signal inputs of the system being driven. Under circumstances where the connection places the Model 202A in series with a path carrying current, distortion of the Model 202A output will occur if greater than 10 ma peak current is caused to flow through the Model 202A output system.

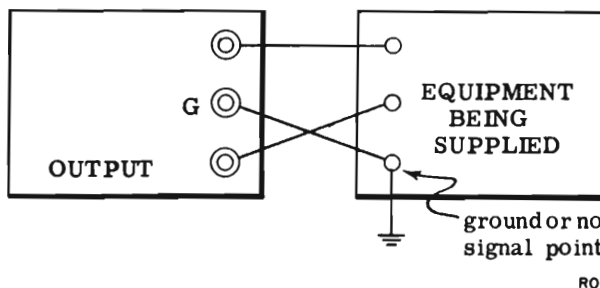

Figure 2-2. Balanced Output Connections

2-7 SYNC. OUT

The SYNC. OUT is a negative pulse of less than 5 microseconds duration and at least 10 volts peak amplitude. It occurs on one of the sine and triangular crests and at the rise or fall of the square-wave. It occurs at the positive crests with respect to one of the OUTPUT terminals and at the negative crest of the other. Therefore, it can be changed by 180° with respect to the output system by reversing connections to the two OUTPUT terminals which are otherwise completely interchangeable. The SYNC. OUT terminal marked "G" is directly connected to the chassis.

SECTION III PRINCIPLES OF OPERATION

3-1 GENERAL

Figure 3-1 depicts the general scheme of the Model 202A and indicates the waveforms produced. The bi-stable circuit consists of a flip-flop circuit capable of producing a square-wave output at point A, provided it is triggered at the proper time. This is done by including in the bi-stable circuit, a two-way comparator circuit which produces the proper triggers for the flip-flop whenever the switching signal becomes equal to either the "plus switching reference" or the "minus switching reference". The triangular switching signal returned to the bi-stable circuit

is that seen between points B and D. The conversion of square wave to triangular wave takes place in the integrator unit which is carefully designed to produce an accurate integral of the applied square wave. The bi-stable circuit and linear integrator are loop coupled in such a manner that the resulting relaxation oscillator is suitable for very low frequency operation.

The sinewave output is taken from a point C between the triangular voltage at point B and the average level at point D. The resistance between C and D is fixed, and the network between C and D is a

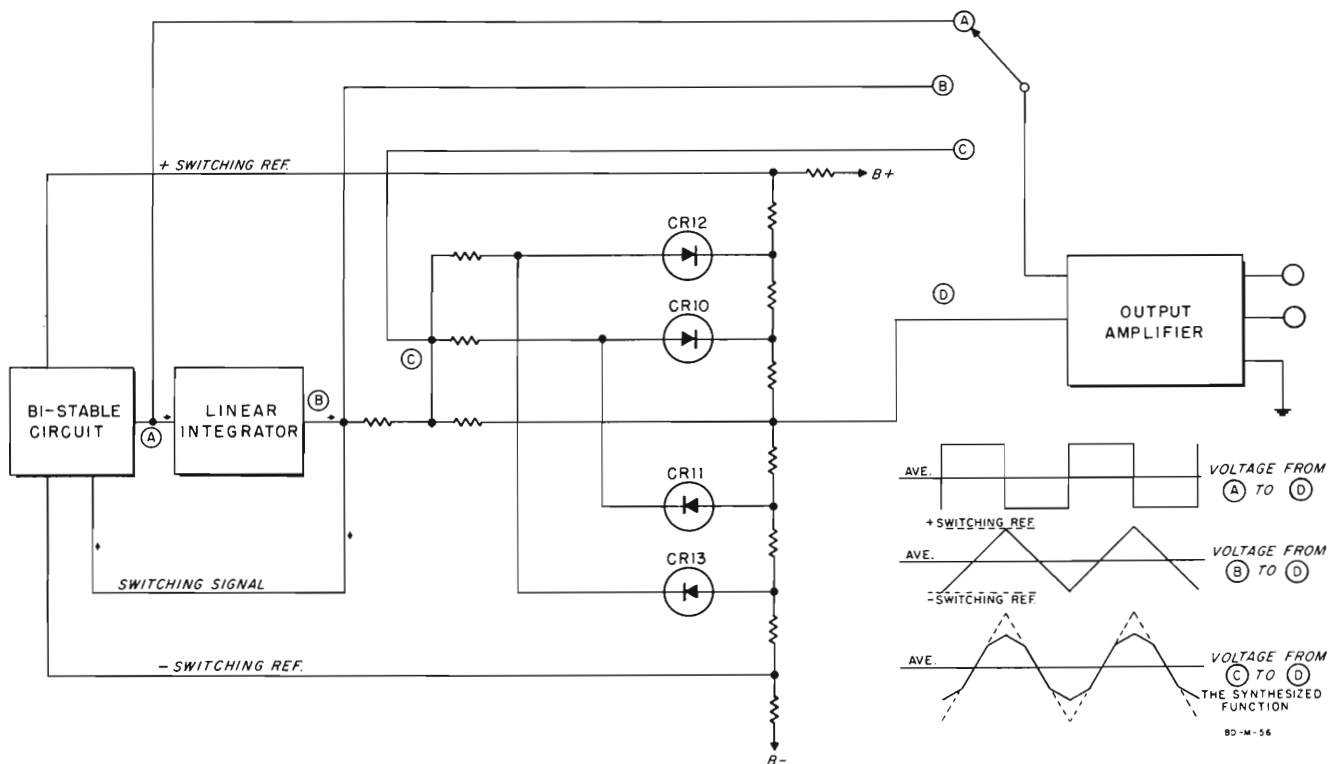

Figure 3-1. Model 202A Function Generator

non-linear system which synthesizes a sine wave from the triangular wave. This network consists of a group of biased diodes arranged in such a manner that at certain predetermined voltage levels they begin to conduct, therefore, providing shunt paths from C to D. Each additional shunt path reduces the slope of the triangle in the proper amount so that the wave is shaped to approximate a sine wave.

This approximation is as shown, and the degree to which a sine wave may be approached depends on the number of diodes. Thus there are available the sine wave C, triangular wave B, and square-wave A functions with respect to D to be selected and brought to the OUTPUT terminals through the output amplifier. The output amplifier has a differential input and push-pull output.

3-2 BI-STABLE CIRCUIT

Figure 3-2 shows the details of the bi-stable circuit and includes the integrator in block form in order to indicate the bilateral connection from integrator output to comparator input.

The portion of the diagram composed of V1, V2 and V3 is the "bi-stable circuit". Actually, this circuit is a combination of two circuits. If capacitors C10 and C13 are disconnected so that there is no possibility of inductive coupling from grids to cathode of V1 and V2, the remaining circuit is the well-known "flip-flop" or Eccles-Jordan trigger circuit. The other circuit which appears in the bi-stable circuit is a voltage comparator known as the "Multiar". The multiar is a circuit which employs a regenerative loop to produce a pulse when the two input voltages are equal. There are two of these in the bi-stable unit. One multiar is composed of V1, V3A and T2, and the other of V2, 3B and T1.

The cathode of V3A and the plate of V3B are connected to reference voltages derived from the voltage regulator tubes V5 and V6. The triangular wave is applied to the plate of V3A and the cathode of V3B. As the voltage on the plate of V3A rises towards the plus switching reference, V1 is conducting, but when V3A conducts, a negative pulse is formed on the grid of V1 which flips the Bi-Stable Unit to its other stable state and starts the voltage on the cathode of V3B towards the minus switching

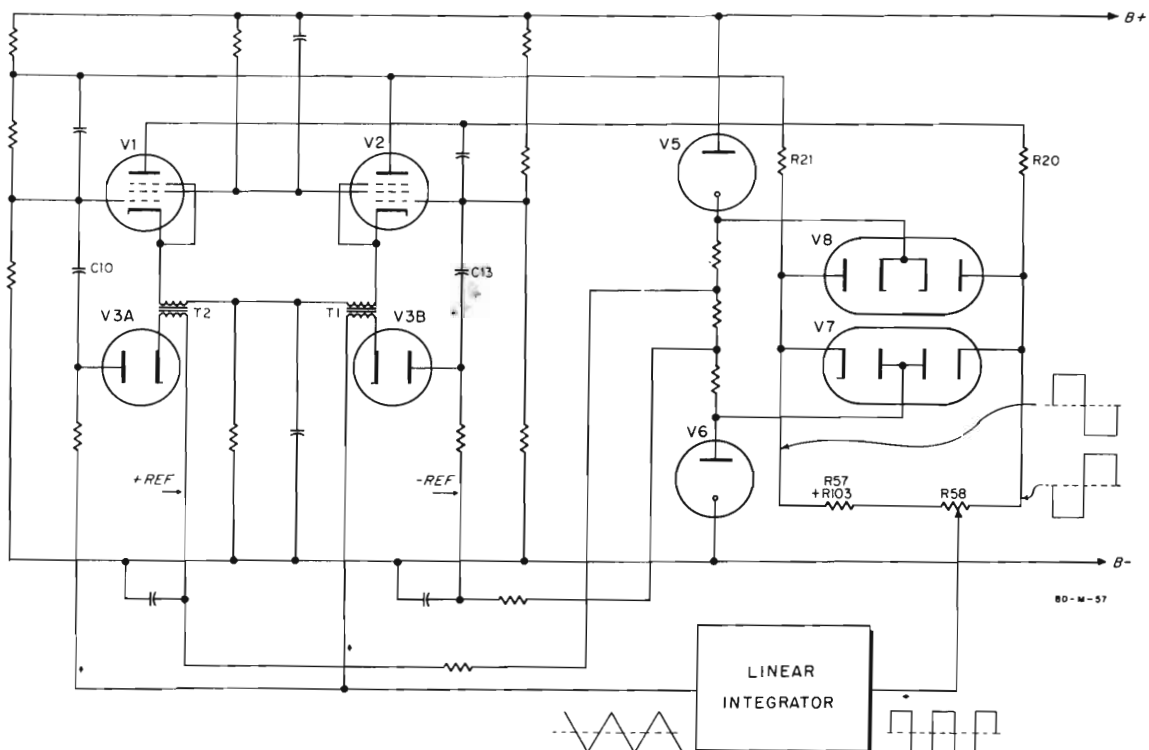

Figure 3-2. Details of Bi-Stable Circuit and Switching System

reference. When V3B conducts the Bi-Stable Unit is flipped back to its original state, completing one cycle of operation.

Voltage regulator tubes V5 and V6 are connected by a voltage divider from which the switching reference voltages are taken. They also provide the limiting voltages applied to tubes V7 and V8 which are seen to be a push-pull clamping system. Inasmuch as the integrator output is directly related to the input, it is seen that the magnitude of squarewave applied must be carefully controlled. Although only the squarewave appearing at the plate of V1 is needed to drive the integrator, the clamp is made push-pull to prevent excessive current variations in the regulator tubes. The action of V7B and V8B is such that if the applied waveform has peak excursions in excess of the potentials on the remaining cathode and plate, these being determined by regulator tubes V5 and V6, a current will flow through R20 which drops the voltage to very nearly the potential of the regulated element of the conducting section of the diode. The action of the other diodes is the same, but 180° out of phase, inasmuch as they are coupled to the plate of V2. In this way, waveforms appearing on the clamped sides of R21 and R20 are assured to be of equal magnitude as well as 180° out of phase, and further the average of dc level of the squarewave is accurately controlled.

3-3 LINEAR INTEGRATOR

Consider the block diagram of the linear of feedback integrator as shown in Figure 3-3. Starting with the output voltage E_o , it is seen that if the gain of the amplifier is high, then the signal appearing at the junction of R and C (the amplifier input) must be small. For a fixed output E_o as the gain is increased the resultant signal at the input of the amplifier becomes arbitrarily small. Since the voltage at the junction at R and C is arbitrarily small, a squarewave applied to the input will cause a constant current in R. Because the current charging and discharging C is constant, except for direction, the voltage across C will be triangular. Since there

is virtually no signal at the junction of R and C the output voltage must also be triangular.

In this case the frequency of the applied signal is so low that the amplifier used must be direct coupled. There is a net voltage rise between input level and output level in a dc amplifier. In this particular application the average output level is determined as the average of the "plus reference" and "minus reference" levels, since the output excursion is limited to these levels. If this level does not coincide with the average level of the applied squarewave, then the positive and negative excursions of the squarewave will not be equal, resulting in unequal rise and fall rates of the output triangle. Because the squarewave input is generated from the triangular output by the bi-stable circuit, the net result is that under such conditions the squarewave is really a rectangular wave. The resulting rectangular wave has an average value just equal to that demanded of the amplifier input by virtue of the pre-set output level. The average levels of the input and output are stabilized by the use of a differential amplifier that has high gain to the difference between the voltage applied to its inputs but little or no gain to any voltage change common to both inputs.

Figure 3-4 shows how this is done. The right hand grid of the differential amplifier V15, is the signal input and is driven through R by the rectangular wave appearing on the FREQUENCY control. The average voltage of this rectangular wave is dependent on the clamping levels and the ratio of "on" to "off" time. When the system is adjusted for equal on-off times (squarewave) the average is just the average of the clamping levels. The left hand grid has no signal because the voltage divider which includes the balance control is connected to the no-signal sides of the clamping tubes. However, any change in the clamping level changes the average level appearing on both input grids in the same amount. Due to the large common cathode resistors of V15 and V16 a common mode change has very little effect. The input to the left hand grid has another function. If the balance control R60, is varied slightly, the output of the amplifier will show a considerable change in average level; and therefore

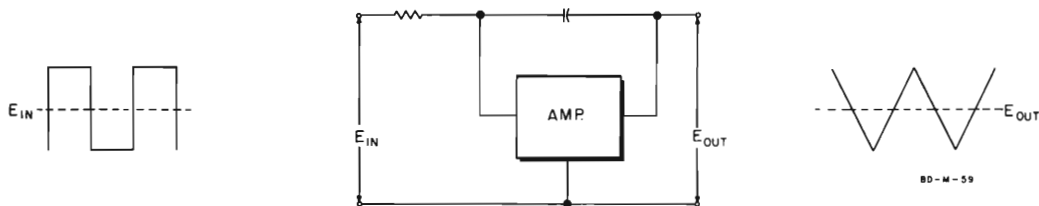

Figure 3-3. Generalized Miller or Feedback Integrator

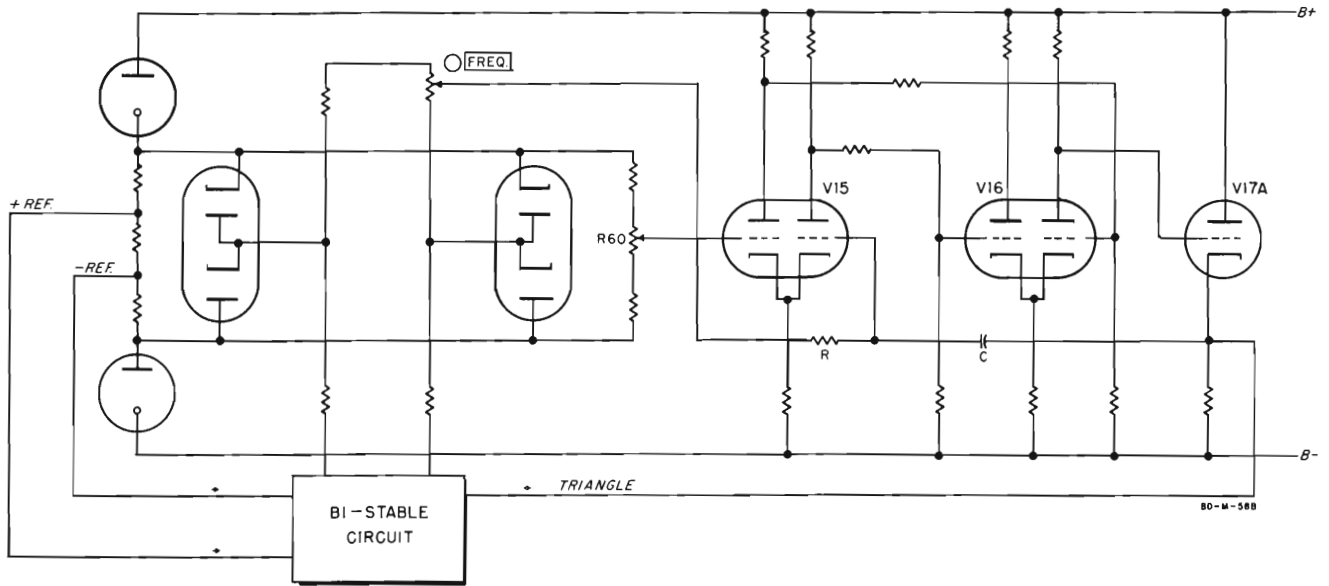

Figure 3-4. Simplified Linear Integrator

the average level of the output can be adjusted to exactly the voltage midway between the "reference" levels. This control then serves adequately to adjust the triangular wave balance which in turn equalizes the on-off time of the squarewave. The signals appearing at the plates of the first tube V15, are 180° out of phase and nearly equal in magnitude. These signals are also very nearly the difference between the inputs on the two grids. Since there is no signal on the left grid, the only signal into the amplifier is that at the junction of R and C, which is the condition originally required. The second stage is a push-pull amplifier employing the signals from the plates of the previous stage. Again the common cathode resistance is very high, but there is very little degeneration of the push-pull input. The gain of the system to changes common to both grids is about one-half while the gain to voltages appearing between the input grids is something over 250. Finally C is fed back to the signal grid from the cathode of V17A which is 180° out of phase with the signal input.

The cathode follower is used as an isolation stage between the integrator and the bi-stable circuit. This completes the oscillating loop with its inherent production of both square and triangular functions.

3-4 SINE SYNTHESIZER AND FUNCTION SELECTOR SWITCH

The triangular wave from the linear integrator is connected to R94. In the SINE position of the FUNCTION selector switch (S3) the other end of R94 is connected to the sine synthesizing diodes and to R93B, one half of the dual AMPLITUDE potentiometer. The synthesized sinewave signal appears as the difference signal between points C and D, but an error signal which appears at D with respect to B- also appears at C with respect to B-. This composite signal is applied to a differential amplifier in the output circuit.

The plus and minus switching references in the bi-stable unit are adjusted so that the ratio of the triangular wave amplitude to the conduction voltages of the synthesizer diodes produces the least distortion of the sinewave. This adjustment also fixes the average voltage at C and is equal to the average of the plus and minus switching references.

The dc voltages at D, and the cathode of V4 are adjusted to be the average of the plus and minus switching references. Since these voltages are equal there is no change in DC level applied to the Output Amplifier as the AMPLITUDE control is varied.

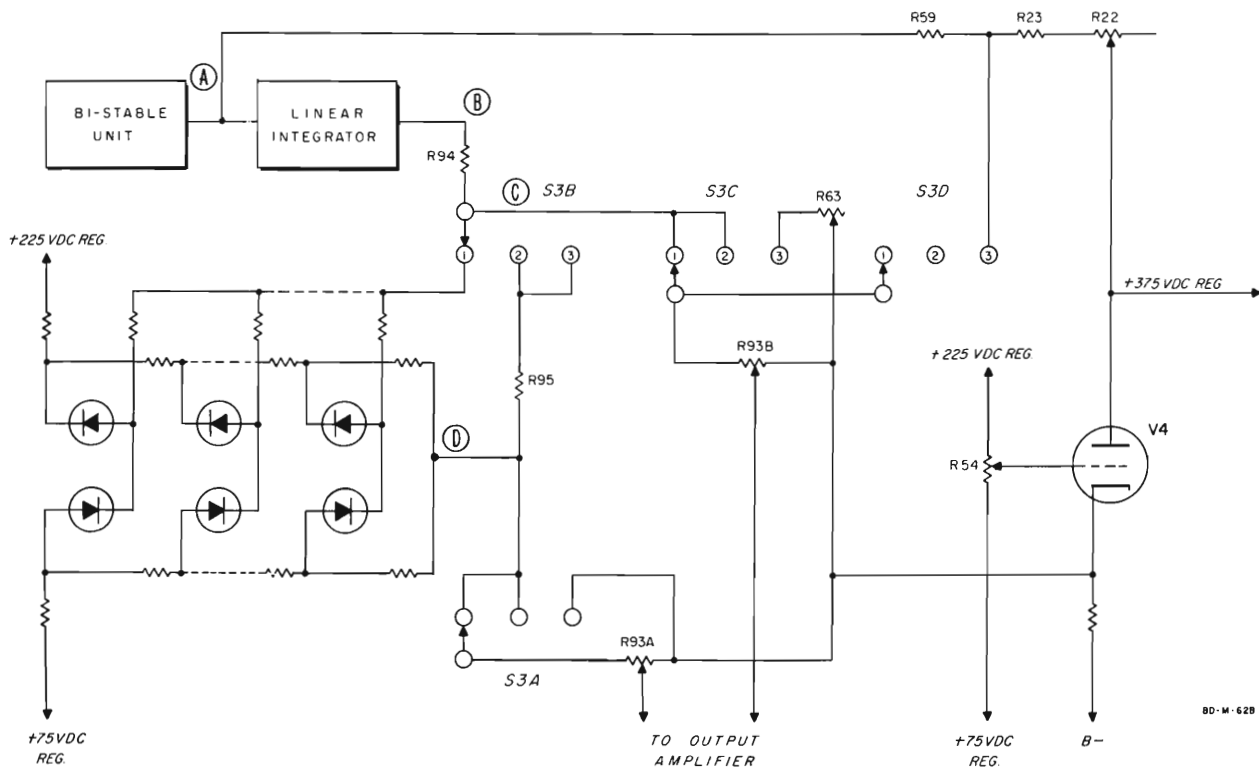

Figure 3-5. Sine Synthesizer and Function Selector



(A) Waveform from integrator output to B-. Triangular regardless of function selector position.



(B) Waveform from (C) to B- with selector switch in sine position. Note distortion especially at peaks.



(C) Waveform from (D) to B- with selector switch in sine position. This is the distortion component present in waveform (B) above.

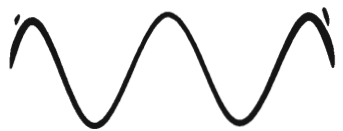

(D) Waveform from (C) to (D). (i. e.: difference between waveforms (B) and (C) above.) This is the approximated sinewave.

RO

Figure 3-6. 50 ν Waveforms

The sinewave is approximated by varying the shunt resistance across R93B is steps determined by the diode synthesizing network. The waveform slope, at first, is just that determined by R94, R93B and the input waveform. When the first diode conducts R93 is shunted by a predetermined amount, decreasing the slope. Each diode in turn decreases the slope until all the diodes are conducting and the triangular wave has reached its crest. The triangular wave starts down, the diodes stop conducting in turn until the triangular wave has reached its crest. The triangular wave starts down, the diodes stop conducting in turn until the triangular wave reaches the average level. The other half-cycle is formed in the same manner, but by the diodes that are biased to shape the negative excursion.

It can be shown that using seven segments to approximate one quarter cycle of the sinewave results in approximately 1/6% rms distortion. However, variations in the diodes limit the practical result to about 1% rms distortion.

In the triangular wave position of the FUNCTION selector switch the non-linear load consisting of the diode network is replaced by R95 so that the combination R94 and R95 is a simple linear divider for all voltage levels. It is adjusted to give equal

sine and triangular wave peak magnitude. The squarewave is connected to the FUNCTION selector switch through the divider R59 and R22 which adjusts the average voltage of the squarewave to the voltage at the cathode of V4. In the squarewave position of the selector switch, R63 parallels R93B to adjust the amplitude of the squarewave to be equal to the amplitude of the sinewave and the triangular wave.

3-5 OUTPUT SYSTEM

The output system consists of three stages as shown in Figure 3-7. The first stage V18 is a dual triode acting as a pair of separate cathode followers. These cathode followers isolate the signal input from the output stage. Any dc unbalance at the output terminals can be corrected by varying R65.

The second stage V19 is a differential amplifier. The difference between the two signals at its grids appears at both plates in nearly equal magnitudes and 180° out of phase. This effect is due to the large common cathode resistance. In this stage amplification takes place and also the signal difference E minus F is converted to push-pull voltages. The third stage V20 is another pair of cathode followers. The signals appearing at the plates of V19 are

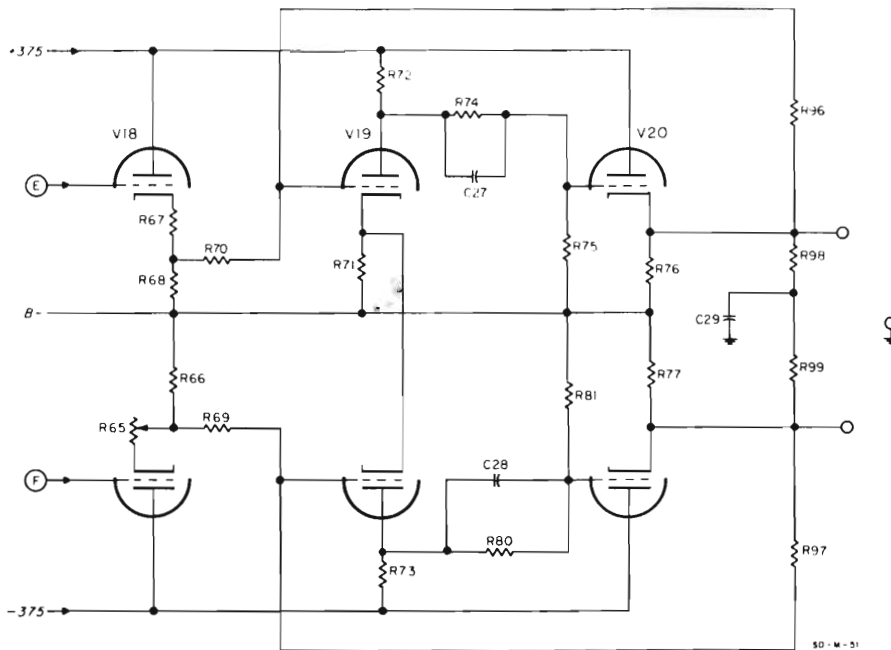

Figure 3-7. Output Amplifier System of Model 20A

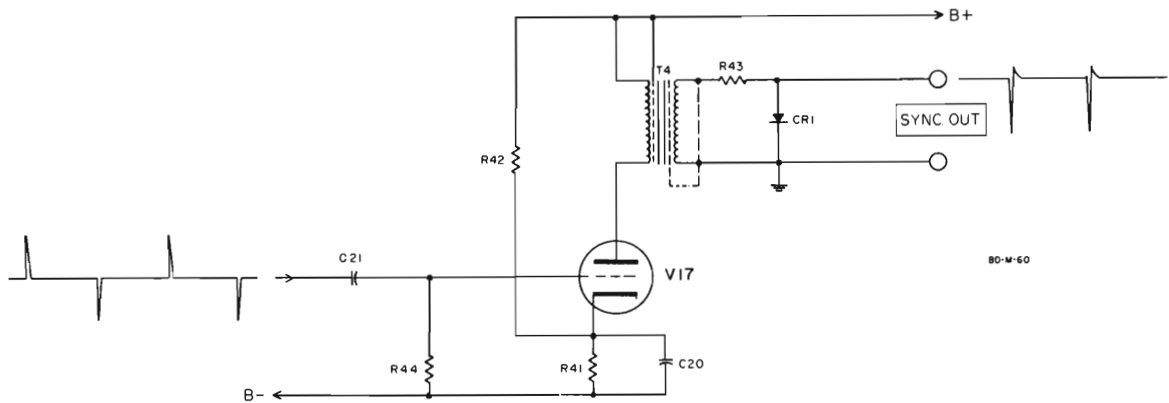

Figure 3-8. Sync Output Circuit of Model 202A

attenuated before being applied to the cathode follower grids. The small shunt capacitors on the upper sides of the dividers improve the high frequency response of the amplifier. The voltages appearing at the cathode follower output terminals are equal in magnitude and 180° out of phase. Negative feedback is used to reduce distortion, lower the output impedance and improve stability. This improved stability applies not only to the signal output, but to the dc level at the output terminals.

connection is desired. It is possible to consider the two output terminals as a transformer output and further to balance this apparent transformer to chassis by making R98 equal to R99. The capacitor C29 insulates the apparent transformer secondary from ground. If single-ended operation is desired the ground connection can be tied to either output terminal without affecting the amplifier.

The symbol for chassis or ground is used for the first time in the output terminal network R98, R99 and C29. In all other description the reference level for operation has been B-, and in the Model 202A the B- line is completely isolated from the chassis. Thus, the chassis ground is available for whatever

3-6 SYNC PULSE OUTPUT

The output sync pulse is obtained from the bi-stable circuit V1 and V2. On the minus switching reference at the plate of multiar diode V3, one positive pulse and one negative pulse appear for every cycle of operation. These pulses are coupled to the grid

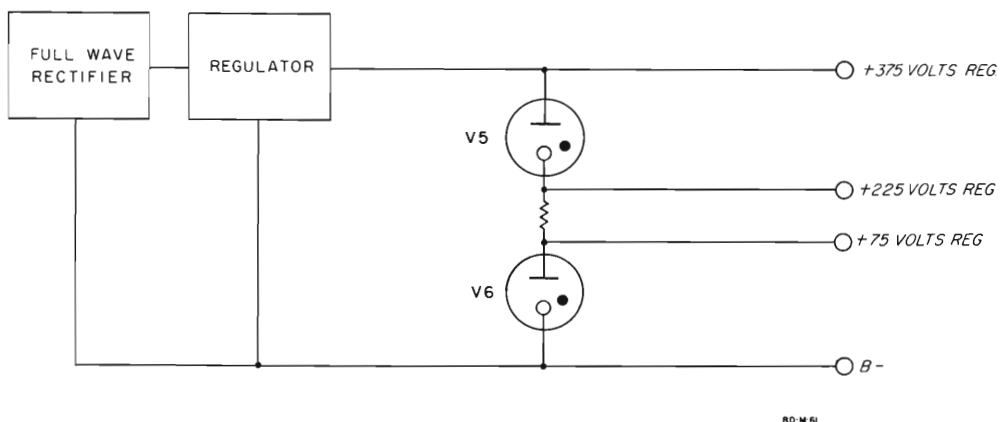

Figure 3-9. Model 202A Power Supply

of the sync pulse amplifier, V17, through an RC coupling which lowers the average voltage on the grid to B-. In the absence of pulses, V17 is biased to cut-off by the bleeder to B+. When a positive pulse appears at the grid, it momentarily turns V17 "on", thus, inducing a large voltage swing in the pulse transformer primary. The resistor and diode in the secondary remove the positive excursion, resulting in a negative pulse at the SYNC OUT terminals.

3-7 POWER SUPPLY

The Power Supply is a full wave rectifier and regulator which supplies +375 volts. The +75 volt and +225 volt regulated outputs are taken from a voltage divider across the +375 volt supply. The main requirement on the three regulated voltages is very low impedance at low frequencies. Reasonable variations in the actual voltages do not affect the output frequency or waveform.

SECTION IV MAINTENANCE

4-1 GENERAL

Most of the following analyzing and adjustment procedures require the measurement of dc voltages or the observation of waveforms. To obtain accurate results, use a voltmeter with an input resistance of 100 megohms or more. The ϕ Model 410B Vacuum Tube Voltmeter is recommended.

All dc voltages are measured with respect to B- and not with respect to the chassis. The B- points in the instrument are connected with black hook-up wire.

CAUTION

Isolate all test equipment from the main chassis or ground. Otherwise, both B- and one side of the output may be connected to the main chassis through the test equipment. If this happens, one cathode resistor in output stage V20 will be shorted and the tube will be severely damaged.

Whenever possible the instrument frequency should be set to approximately 50 cycles/sec. to permit the use of a capacitor in series with the ac voltmeter or oscilloscope to eliminate the dc component.

Interaction between most of the circuits of the Model 202A makes a fairly definite procedure for trouble shooting necessary. For example, a fault in the oscillator section may easily cause considerable voltage deviations in the output system. Therefore, it is more desirable to divide the instrument into five sections as follows and consider each in turn.

- 4-2 Power Supply
- 4-3 Function Generator
- 4-4 Sine Synthesizer and Function Selector
- 4-5 Output Amplifier
- 4-6 Sync Out

4-2 POWER SUPPLY

After power supply parts replacements or adjustments, a final check of regulated voltages should be made. See Power Supply Regulator Adjustments in paragraph 4-9.

TABLE 4-1

SYMPTOM	CAUSE AND/OR REMEDY
Instrument inoperative (Indicator lamp won't light, no output voltage).	Blown fuse, F1.
Instrument inoperative (Indicator lamp lights, no output voltage).	Measure resistance from V21 socket (pins 2 or 8) to B-. 55,000 ohms or more replace V21. If less than 55,000 ohms clear short circuit in filter or regulator circuits then replace V21.
Instrument inoperative (normal voltage at V21). (Extremely low or no voltage between V5, pin 5 and B-).	Defective 6AU5 tubes (V22, V23). Capacitor C6 short circuited.
Instrument inoperative (normal +375V regulated) (+225V regulated, off voltage). (+75V regulated, off voltage)	Defective OA2 tube (V5). Defective OA3 tube (V6).
Instrument inoperative (No +225 regulated +75 regulated voltages, V5 and/or V6 not ionized).	Open circuit in R62, R84, R85, R91, or R92.

**4-3 FUNCTION GENERATOR
(bi-stable circuit and integrator)**

A. REPAIR ANALYSIS OF FUNCTION GENERATOR

If replacing tubes does not restore the triangle voltage, then a simple test should be made to determine whether the fault is in the integrator or the bi-stable circuit. This test is as follows:

- 1) Connect a high resistance dc voltmeter between B- and pin 3 of tube V17.
- 2) Set the RANGE switch to the X.01 position. Disconnect the lead from the center lug of the variable resistor R58. Temporarily connect this lead to pin 5, V6 (+75 Reg.).
- 3) After this connection is made, the voltage indicated by the voltmeter should slowly climb until it is over 200 volts.
- 4) Remove the lead from the +75 Reg. supply and connect it to pin 2, V5 (+225 regulated). The voltmeter indication should now drop slowly to less than 140 volts. Disconnect the lead from V5 and return it to the original connection on R58.
- 5) If the instrument meets the above voltage requirements, then the integrator section is functioning normally and the fault is confined to the bi-stable circuit. If the instrument does not pass the test, then the trouble is in the integrator.

After all defective parts have been replaced and the necessary adjustments made, an oscilloscope should be connected between pin 3, tube V17 and B- to see if a good triangular waveform is obtained on all ranges.

TABLE 4-2.

SYMPTOM	CAUSE AND/OR REMEDY
No output voltage (Power Supply Section normal, no triangle voltage between V17, pin 3 and B- on any range).	Replace V1, V2, V3, V15, V16, or V17. If tube replacement fails to cure the trouble, see analysis procedure following this chart.
Same symptoms as above on one or more ranges.	Check RANGE switch contacts, components, and connections. Check C14-C18 for excessive leakage.

TABLE 4-2. (CONT'D)

SYMPTOM	CAUSE AND/OR REMEDY
Same symptoms as above when frequency dial is set near low frequency end.	Try replacement tubes for V15, V16, and/or V17.
Triangle not linear.	Replace tubes V15, V16, V17. Check DC Balance.

4-4 SINE SYNTHESIZER AND FUNCTION SELECTOR

When the trouble has been corrected in the Sine Synthesizer and Function Selector, the following checks should be made to determine if the instrument is again functioning correctly.

- 1) Sine Wave - Observe the waveform between pin 2, V18 and B- with oscillator set to 50 cycles/sec. and the AMPLITUDE control at maximum. Set the FUNCTION switch in the SINE position. The waveform should be substantially sinusoidal and approximately 30 volts peak-to-peak. See Figure 3-6B.

Observe the waveform between pin 7, V18 and B- with the same conditions as above. The waveform should be similar to Figure 3-6C and approximately 1 volt peak-to-peak.

- 2) Triangular Wave - Observe the waveform between Pin 2, V18 and B- with the oscillator set to 50 cycles/sec. and the AMPLITUDE control at maximum. Set the FUNCTION switch in the TRIANGULAR position. The waveform should be triangular and approximately 30 volts peak-to-peak.

Observe the waveform between pin 7, V18 and B- with same conditions as above. The waveform should be triangular and approximately 1 volt peak-to-peak.

- 3) Square Wave - Observe the waveform between pin 7, V18 and B- with the oscillator set to 50 cycles/sec. and the AMPLITUDE control at maximum. Set the FUNCTION switch to the SQUARE position. The waveform should be square and approximately 30 volts peak-to-peak.

The dc voltage across the OUTPUT terminals should be adjustable to zero under any operating conditions by means of R65.

TABLE 4-3.

SYMPTOMS	CAUSE AND/OR REMEDY
Sinewave badly distorted.	Maladjustment of R49, R51, and R60 or defective diodes CR2 through CR13.
DC component at OUTPUT terminals independent of AMPLITUDE control setting or varied by AMPLITUDE control.	Maladjustment of R65, R54, and R118 or defective tubes V4, V18, V19, V20. See DC Balance Adjustment.

4-5 OUTPUT AMPLIFIER

TABLE 4-4.

SYMPTOMS	CAUSE AND/OR REMEDY
Increased distortion when amplifier is loaded with 4000 ohms.	Replace V18, V19, V20. If distortion remains, turn off the power and measure resistance between internal chassis and main chassis. See paragraph 4-9.
DC voltage component exists across the OUTPUT terminals.	See paragraph 4-4.
Distortion increases appreciably with reduced AMPLITUDE control setting.	Replace variable resistor R93A, R93B.
Failure to deliver 10 volts rms sinewave output.	Adjust regulated B+ voltage. See paragraph 4-9.
Hum in output voltage.	Replace V18, V19, V20. Excessive hum from power supply. See paragraph 4-9.

After adjustment or tube replacement, the amplifier should meet the following specifications:

- The output voltage should not drop more than 2% when a 4000 ohm load is connected to the output.
- The distortion should remain within specifications when the output is loaded with 4000 ohms or higher.
- The peak-to-peak output voltage should be at least 30 volts (10.6 volts rms with a sinewave) when the output is loaded with 4000 ohms or higher.

4-6 SYNC OUT

Specifications call for a negative sync pulse of 10 volts peak with a duration less than 5 microseconds. The sync pulse occurs at the sinewave crest and at corresponding positions on other waveforms.

TABLE 4-5.

SYMPTOMS	CAUSE AND/OR REMEDY
No sync pulse (Check for negative pulse with oscilloscope and with Model 202A set for highest frequency).	Replace V17.
Large overshoot.	Replace CR1.

4-7 TUBE REPLACEMENT

Any tube with standard JETEC characteristics can be used for replacement purposes.

Whenever a tube is replaced, that part of the instrument which might be affected by the change must be tested and if necessary, adjusted to be within specifications. See paragraph 4-8, Tube Replacement Chart.

4-8 TUBE REPLACEMENT CHART

TABLE 4-6.

TUBE	EFFECT	READJUSTMENT
V1, V2	None. Variations in bottoming voltage eliminated by clamps V7 and V8.	None.
V3	Frequency shift and distortion increase due to contact potential variations.	Min. Distortion and Correct Freq. Adj.
V4	DC output level shift, probably as a function of amplitude control setting.	DC Bal. Adj.
V5, V6	Possible change in frequency, distortion, or dc balance from change in regulated voltages.	Power Supply. DC Bal Adjust. Minimum Distortion and Correct Freq. Adjust.
V7, V8	Same effect as change in V3 possible, but to much less degree.	Min. Distortion and Correct Freq. Adj.
V15, V16, V17	Frequency change and unbalance of triangle.	Min. Distortion and Correct Freq. Adj.
V18, V19, V20	Change in dc output component, independent of AMPLITUDE control setting.	Set dc output component to zero by R65, with amplitude control min.
V21	No effect	None.
V22, V23, V24, V25	Possible change in + 375 and + 225 regulated voltages.	Carry out procedure under "Power Supply Regulator Adjustment". Paragraph 4-9.

4-9 POWER SUPPLY REGULATOR ADJUSTMENT

Resistance measured between inner and outer chassis should be at least two megohms with **OUTPUT** terminals disconnected from panel ground or a load. This resistance check should be made before starting the following adjustment procedure:

1) Connect the shorting strap between the lower output terminal and chassis ground. Connect the dc voltmeter between **B-** and the inner chassis. The voltmeter must not be grounded and the common terminal should be connected to **B-**.

2) Connect the 202A to the power line and turn on. The voltmeter indication should be between +190 and +230 volts with line voltage set to 115 volts.

3) Measure the regulated output voltage between **B-** and pin 2 of tube V5. Adjust control R11 to give a voltage of +225 volts.

4) Measure the voltage between pin 5 of tube V5 and **B-**. This voltage should be about +375 volts. Variations in OA3 tubes can cause this voltage to be as low as 365 or as high as 393.

5) Measure the voltage between pin 5 of tube V6 and B-. This voltage should be about +75 volts. Variations in OA3 tubes can cause this voltage to fall at any point between 68 and 85 volts.

6) Repeat step 3 if you replace either V5 or V6. The characteristics of cold-cathode regulator tubes drift during about the first 72 hours of operation. This drift can affect the 202A output. A 72 hour aging is recommended for a new tube for either V5 or V6.

7) Test the regulated output voltage at pin 5 of tube V5 while varying line voltage between 103 and 127 volts. The regulated voltage will normally not change by more than $\pm 1\%$. Check power supply tubes and components if the change is excessive.

4-10 THEORY OF DC BALANCE AND DISTORTION ADJUSTMENTS

The output AMPLITUDE control is located at the input to the output amplifier. If the dc component at the output terminals is to be zero for all settings of the AMPLITUDE control the dc levels at the ends of the AMPLITUDE control must be the same and also equal to the average level of the input wave. From the schematic wiring diagram, it is seen that the common connection between the two sections of the control is connected to the cathode of V4. The level of this point can be adjusted to the desired value by R54. The signal impedance of this point is very low compared with the magnitude of the AMPLITUDE control impedance, and therefore, the cathode of V4 has virtually zero signal.

When R49, R51, R54, and R60 are adjusted properly, there is no dc component across either section of the AMPLITUDE control.

When the FUNCTION switch is in the squarewave position, there is no signal input to one section of the AMPLITUDE control, hence, the tap on that section merely carries the constant bias level set by the cathode of V4. The other section is connected through a network to the clamp section of the bistable circuit. R22 of this network adjusts the average level of the squarewave applied to the amplitude control to the same value as the cathode of V4.

The dc levels at the input to the amplifier are independent of AMPLITUDE control setting. The dc levels of the two output terminals may be adjusted to be equal by R65. Control R65 varies the dc level of the signal on one grid of the second stage of the amplifier. When these adjustments are made, the dc component between the output terminals will remain at a very low value, independent of amplitude setting or waveform selected.

Control R49 varies the level to which the output of the integrator rises in a positive direction and R51 varies the level of the negative excursion. The bias levels of the shaper diodes are not variable and therefore, the triangle input to the shaper can have one and only one correct magnitude and average level.

Figure 4-2 shows the situation at the shaper when the two reference levels are properly adjusted. Figure 4-2B shows the effect of having the reference levels adjusted for too large a magnitude, but with the proper average value. Figure 4-2C shows the effect of having reference levels adjusted for a triangle of the proper magnitude, but incorrect average level. This indicates a close relationship between correct frequency calibration and minimum distortion. In fact, the two conditions are simultaneously satisfied by optimum settings of the same adjustments.

4-11 DC BALANCE AND DISTORTION ADJUSTMENTS

The following test procedure requires a dc voltmeter with an input resistance of at least 100 megohms such as an ϕ Model 410B. In addition, the voltmeter must not be grounded as the common side of the meter must be connected to points within the 202A that are not at ground potential. A Distortion Analyzer and an Oscilloscope will also be required.

A 20 minute warm-up is recommended before you start this procedure. You should also adjust the power supply as outlined in paragraph 4-9.

1) Adjust the insulated 410B voltmeter to indicate 0.5 on the 1 volt range with the dc leads shorted. Use either the "+" or the "-" position of the SELECTOR switch -- whichever one will permit the 0.5 setting with the ZERO ADJ. control. This meter indication will be called "0 volts" in the remaining portion of this procedure.

2) Connect the COMMON lead from the voltmeter to the common junction of AMPLITUDE controls R93A and R93B (violet wire).

3) Connect the DC volts probe to the opposite end of R93A. This is a slate wire connected to the AMPLITUDE control.

4) Set the FUNCTION switch to TRIANGULAR and adjust R54 for a voltmeter indication of "0 volts".

5) Move the DC volts probe to the arm of R118 and adjust R118 for an indication of approximately "0 volts".

- 6) Set the **AMPLITUDE** control to minimum (maximum CCW) and move the voltmeter leads to the red **OUTPUT** terminals.
- 7) Adjust R65, located behind a hole in the panel near the **OUTPUT** terminals, for an indication of "0 volts".
- 8) Set R119, located near V1 and T2, to the middle of its range.
- 9) Disconnect the voltmeter and connect equipment as shown in Figure 4-1.
- 10) Set the **FREQUENCY** dial to 10, the **RANGE** switch to **X10** (100 cps), **FUNCTION** selector to **SINE**, and the **AMPLITUDE** control for an output of approximately 10 volts rms.
- 11) Adjust R49 and R51 to eliminate the points or spikes at the ends of the Oscilloscope pattern. Adjustment of these controls will shift the output frequency, you should follow the frequency shift with the Distortion Analyzer. Adjust the Distortion Analyzer sensitivity as necessary to obtain a useful pattern on the Oscilloscope (see Figure 4-3).
- 12) Adjust R60 for minimum distortion as indicated on the Distortion Analyzer. Repeat steps 11 and 12 until the distortion measured is at least 40 db below the output voltage (1%).
- 13) Connect the voltmeter **COMMON** lead to the common junction of **AMPLITUDE** controls R93A and R93B (violet wire).
- 14) Connect the DC volts probe to the opposite end of R93B. This is a green wire connected to the **AMPLITUDE** control.
- 15) Switch the **FUNCTION** selector to **TRIANGULAR** and note the voltmeter indication (0.5 on 0-1 scale is "0 volts"). Adjust R49 to reduce the dc voltage to one-half of its initial value, then adjust R51 to remove the remaining dc voltage. The voltmeter should now indicate "0 volts".
- 16) Set the **FUNCTION** selector to **SINE** and adjust R118 for a voltmeter indication of "0 volts".
- 17) Verify the distortion in the output sine wave at 100 cps, first on the **X10** **RANGE** with the **FREQUENCY** dial at 10, then on the **X100** **RANGE** with the **FREQUENCY** dial at 1. If the distortion indications are not approximately identical, careful adjustment of R119 will lower the 100 cps distortion on the **X100** **RANGE**.
- 18) Connect the voltmeter **COMMON** lead to the common junction of **AMPLITUDE** controls R93A and R93B (violet wire). Connect the DC volts probe to the green wire on the opposite end of R93B.
- 19) Set the **FUNCTION** selector to **SQUARE** and the **RANGE** switch to **X10**. Adjust R22 for a voltmeter indication of "0 volts".
- 20) Any dc between the red **OUTPUT** terminals with the **AMPLITUDE** control at minimum may be eliminated by adjusting R65 (behind the hole in the panel). This voltage should vary less than ± 0.5 volts when the **AMPLITUDE** control is rotated through its full range.

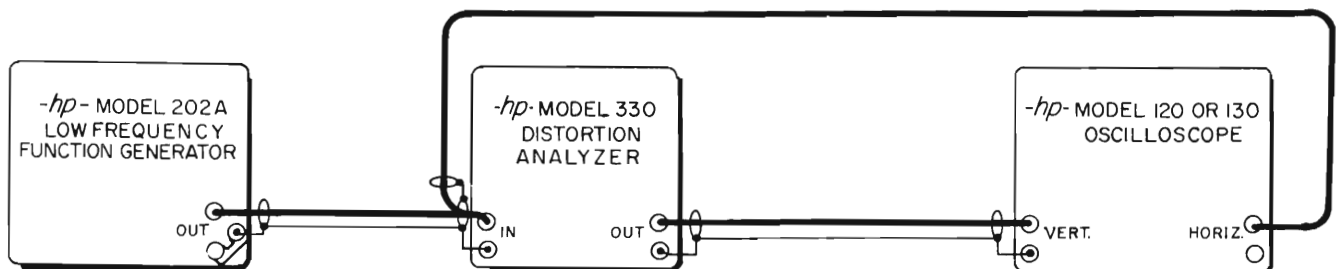

BD-S-38

Figure 4-1. Minimum Distortion and Frequency Adjustment Instrumentation

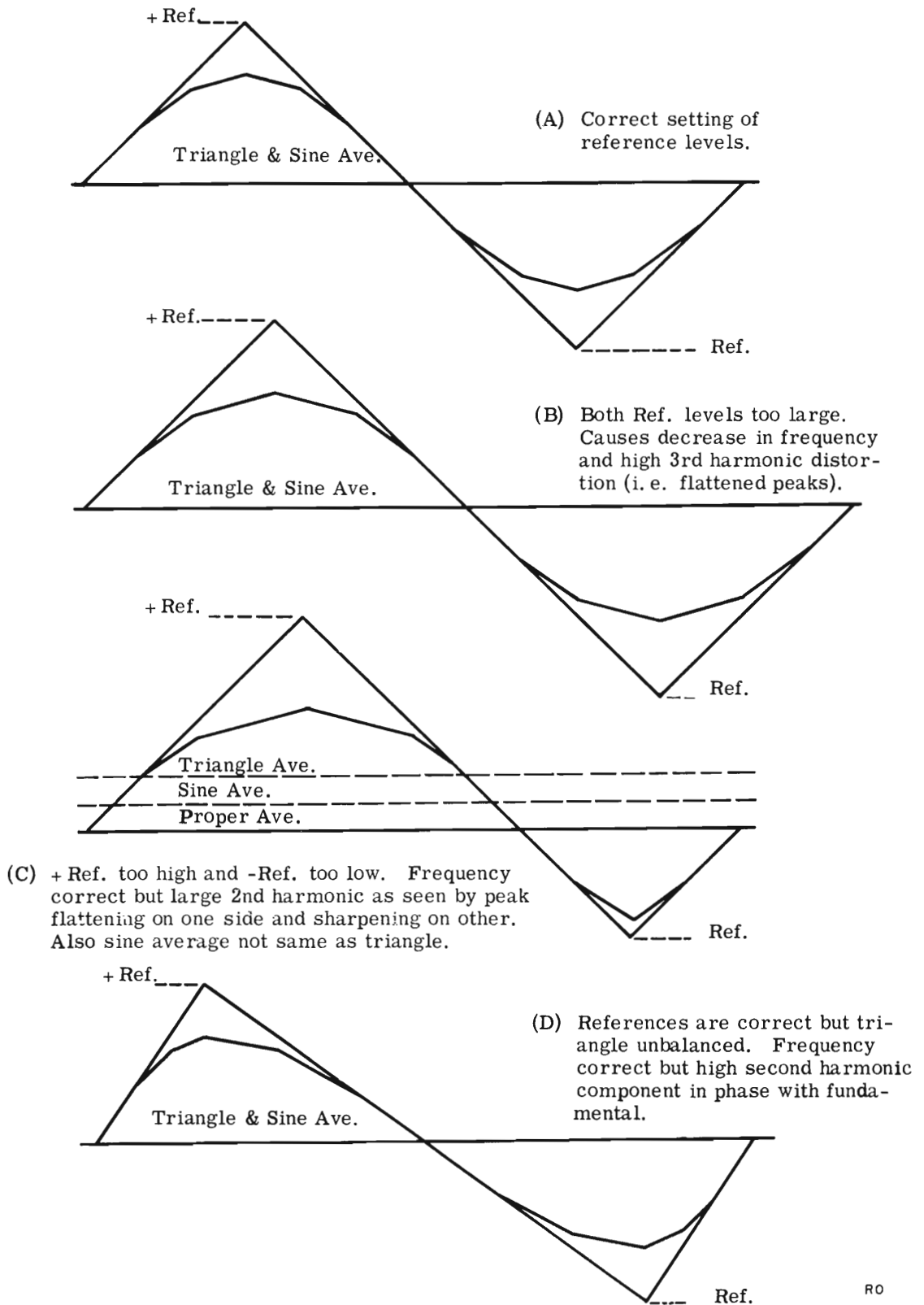
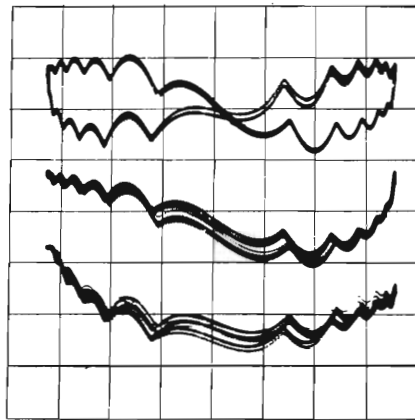
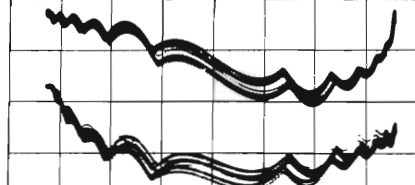

Figure 4-2. Effect of Triangle Maladjustment on Distortion and Frequency. Ten-Segment Approximations Used for Clarity.



A

(A) R60 and R119 misadjusted



B

(B) R51 misadjusted



C

(C) R49 misadjusted

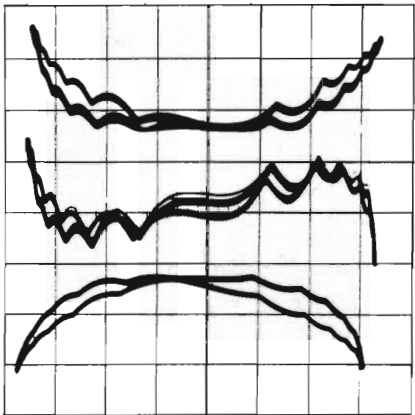

D

(D) R49 and R51 misadjusted in same direction

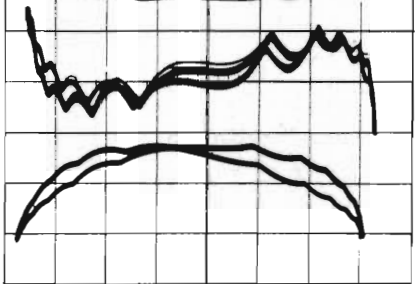

E

(E) R49 and R51 misadjusted

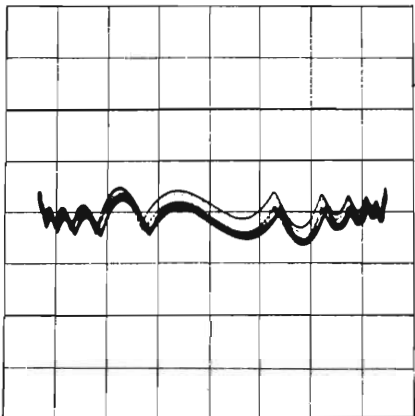

F

(F) R49 and R51 misadjusted in opposite direction of pattern D above

Typical adjusted pattern for minimum distortion and correct frequency

Figure 4-3. Patterns Showing the Adjustments of R49, R51, R60 and R119 to Obtain Minimum Distortion and Correct Frequency

4-12 ADJUST SQUAREWAVE AMPLITUDE

Adjust control R63 to produce an output squarewave with the same peak-to-peak amplitude as the sine and triangular output waveforms.

4-13 FREQUENCY RATIO AND CALIBRATION PROCEDURE

The following procedure is intended for use after replacement of the Range Switch or any of the frequency determining components on the Range Switch. This procedure is also required following replacement of frequency determining potentiometer R58.

- 1) Remove the cabinet or top and bottom instrument covers.
- 2) Check that the upper and lower dial stops fall about an equal distance outside the upper and lower dial calibration marks. Correct the dial setting, if necessary, by rotating the dial on the dial mounting hub. The dial stops and not the potentiometer mechanical stops should be limiting dial travel.
- 3) Turn the 202A on, set the line voltage to 115 volts, turn the FUNCTION switch to "SQUARE", and allow at least a 1 hour warm-up period.
- 4) Adjust power supply, then adjust DC Balance and Distortion.
- 5) Determine the ratio between the two frequencies obtained with the frequency dial at "0.8" and "12" with the RANGE switch at "X1".

Frequency determination is most easily accomplished by measuring the period of the unknown frequency. An electronic counter such as ϕ Model 522B, 523B, or 524B will be needed. A frequency of 0.8 cps has a period of 1250 milliseconds while 12 cps has a period of 83.3 milliseconds.

6) The ratio obtained in step 5 must be 15 to 1. Adjust by loosening the coupler between the dial and potentiometer (R58) shafts. See Figure 4-4 for coupler access hole location. Rotate one shaft with respect to the other to obtain a period of 83.3 milliseconds with a dial reading of 12. Tighten both set screws in the coupler.

7) Set the frequency dial to 0.8 and adjust control R109 to obtain a period of 1250 milliseconds. Check the setting made in step 6 and, if necessary, repeat step 6.

If R109 has insufficient range, center the control mechanically and repeat steps 6 and 7. This will electrically center the adjustment range of R109 which can then be used to make any final adjustments.

8) Check calibration of the "X1" range. The output frequency should be within $\pm 2\%$ of the dial reading over the entire range. Adjust R26B if necessary.

9) Check the calibration of the other ranges. Adjust R24B for the "X.01" range, R25B for the "X.1" range, R27B for the "X10" range and R28B for the "X100" range.

On the "X100" range only, adjust C33 to calibrate the high end of the band.

10) Replace the cabinet or the top and bottom cover.

4-14 REPLACEMENT OF R58 POTENTIOMETER

Replacement of the frequency control potentiometer involves two basic operations:

- 1) The mechanical procedure for replacing a defective potentiometer with a new one.
- 2) The necessary electrical adjustments described in paragraph 4-13.

All necessary specialized instructions are included with the replacement potentiometer.

4-15 PERFORMANCE CHECK

4-16. OUTPUT VOLTAGE AND WAVEFORM CHECK.

1) Connect test setup as shown in figure 4-4, including a 3.9K ohm shunt resistor across the OUTPUT terminals of Model 202A.

2) Set Model 202A controls as follows:

RANGE	X10
FREQUENCY DIAL	10 (100 cps)
AMPLITUDE	full cw
FUNCTION	SINE

3) Set oscilloscope VERTICAL SENSITIVITY to 5 volts/cm.

- 4) Sinewave observed should be sinusoidal and have an amplitude of at least 30 volts peak-to-peak.
- 5) Set FUNCTION to TRIANGULAR.
- 6) Wave observed should be triangular and have an amplitude of at least 30 volts peak-to-peak.
- 7) Set FUNCTION to SQUARE.
- 8) Square wave observed should have an amplitude of at least 30 volts peak-to-peak.

4-17. SYNC PULSE CHECK.

- 1) Connect test setup as shown in figure 4-4, except oscilloscope is to be connected to SYNC. OUT on Model 202A and not to OUTPUT.

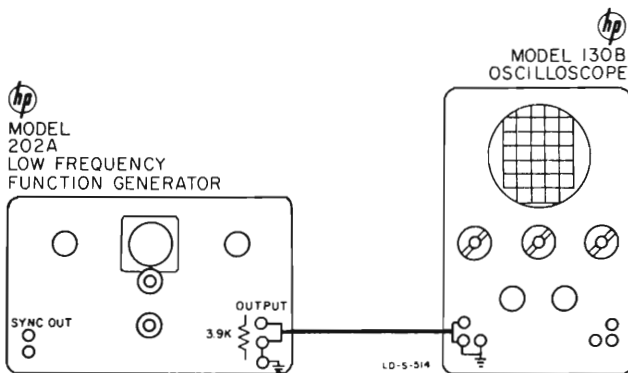

Figure 4-4. Output Voltage and Sync Pulse Test Setup

- 2) Set RANGE to X100 and FREQUENCY DIAL to 10 (1000 cps).
- 3) Set oscilloscope VERTICAL SENSITIVITY to 5 volts/cm and SWEEP TIME to 1 sec/cm.
- 4) The negative pulse observed should be less than 5 sec duration and have an amplitude equal to or greater than 10 volts.

4-18. SINE WAVE DISTORTION CHECK.

- 1) Connect test setup as shown in figure 4-5, including a 3.9K ohm shunt resistor across the OUTPUT terminals of Model 202A.

- 2) Set Model 330B/C/D controls as follows:

INPUT AF
 FREQUENCY RANGE X1
 FREQUENCY DIAL 100 cps
 FUNCTION METER
 METER RANGE 30 RMS VOLTS

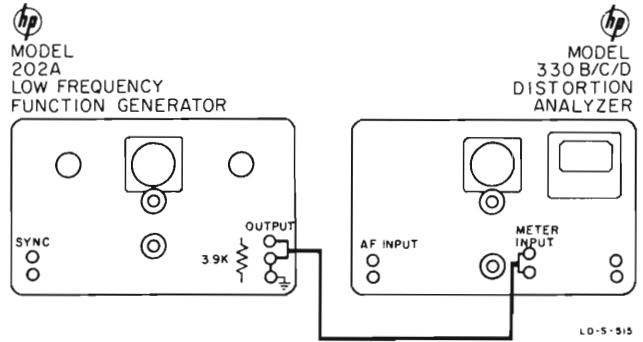

Figure 4-5. Sine Wave Distortion Test Setup

- 3) Set Model 202A controls as follows:
 RANGE X10
 FREQUENCY DIAL 10 (100 cps)
 FUNCTION SINE
 AMPLITUDE adjusted for 10.6 volts output (read on Model 330B/C/D).
- 4) Disconnect cable from METER INPUT and reconnect it to AF INPUT.
- 5) Set FUNCTION to SET LEVEL and METER RANGE to 100%.
- 6) Adjust INPUT SENSITIVITY for 100% on the 10 scale (full scale is 100%).
- 7) Set FUNCTION to DISTORTION.
- 8) Tune Model 330B/C/D for null.
- 9) Set METER RANGE to 3% and retune for null. Reading should be less than 1 on the 3 scale (full scale is 3%).
- 10) On Model 202A change RANGE to X100 and FREQUENCY to 1 (100 cps). Repeat steps 1 through 9 at this frequency. Reading should be less than 2.

4-19. DIAL ACCURACY CHECK.

- 1) Connect test setup as shown in figure 4-6.
- 2) Allow 1/2 hour warmup period.
- 3) Set Model 202A controls as follows:
 RANGE X100
 FREQUENCY 12 (1200 cps)
 FUNCTION SQUARE
- 4) Set Model 523C/D for period measurement as follows:
 FUNCTION SELECTOR PERIOD
 TIME UNIT μSEC
- 5) Model 523C/D should read between 816 and 850.

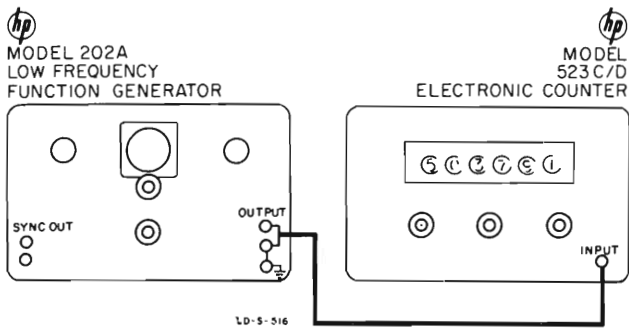

Figure 4-6. Dial Accuracy Test Setup

6) Set Model 202A RANGE to X10 (120 cps) and Model 523C/D TIME UNIT to MILLISEC.

- 7) Counter should read between 8.16 and 8.50.
- 8) Set Model 202A RANGE to X1 and FREQUENCY dial to 1.4 (1.4 cps).
- 9) Counter should read between 699.9 and 728.5.
- 10) Set Model 202A RANGE to X1 (.14 cps).
- 11) Counter should read between 6999.9 and 7284.7.
- 12) Set Model 202A RANGE to X.01, FREQUENCY dial to .8 (.008 cps) and Model 523C/D TIME UNIT to SEC.
- 13) Counter should read between 121.25 and 128.75. Due to such a low frequency the counter may not start its count for approximately 2 min and 5 sec.

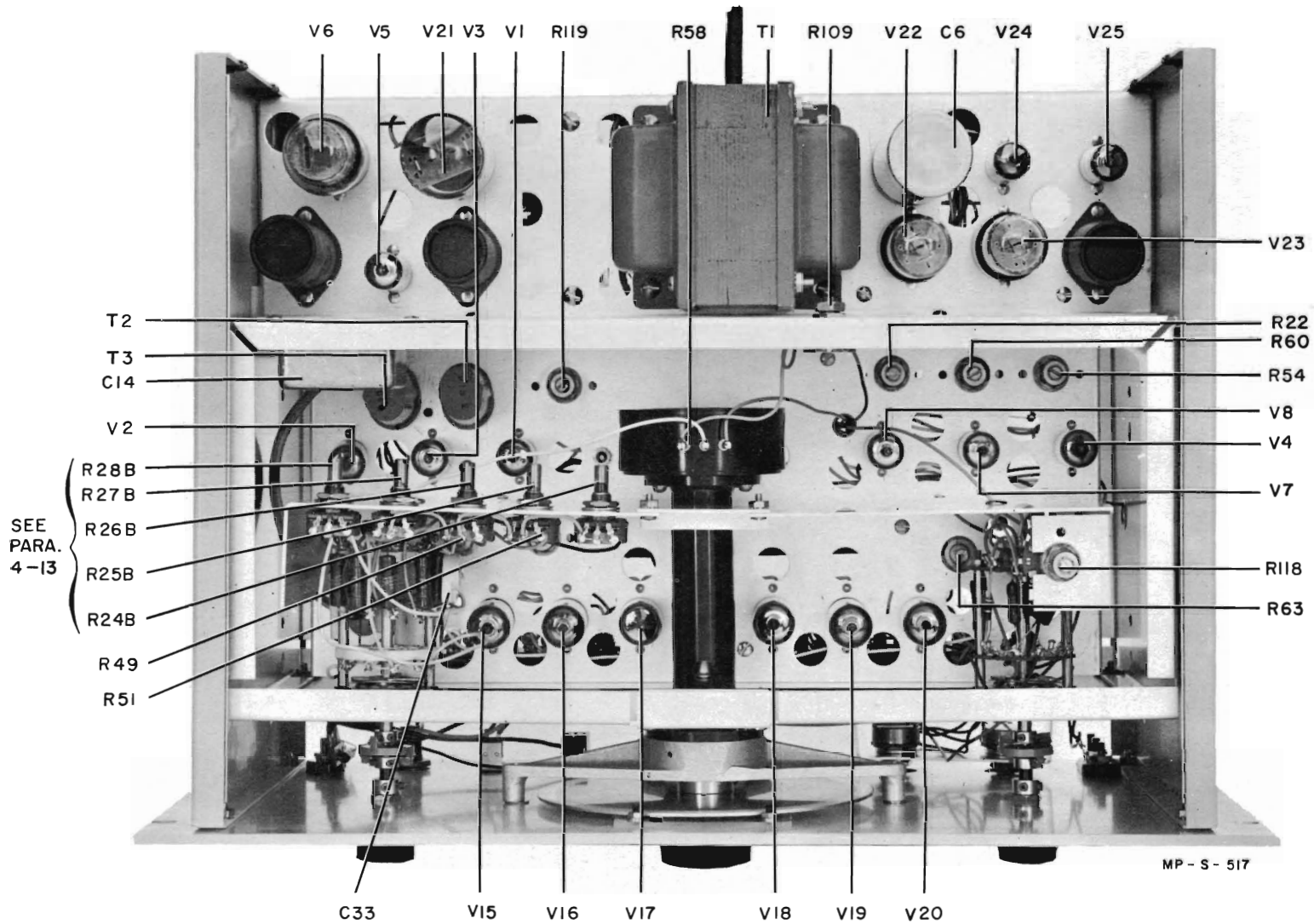

Figure 4-7. Model 202A Top View Cover Removed

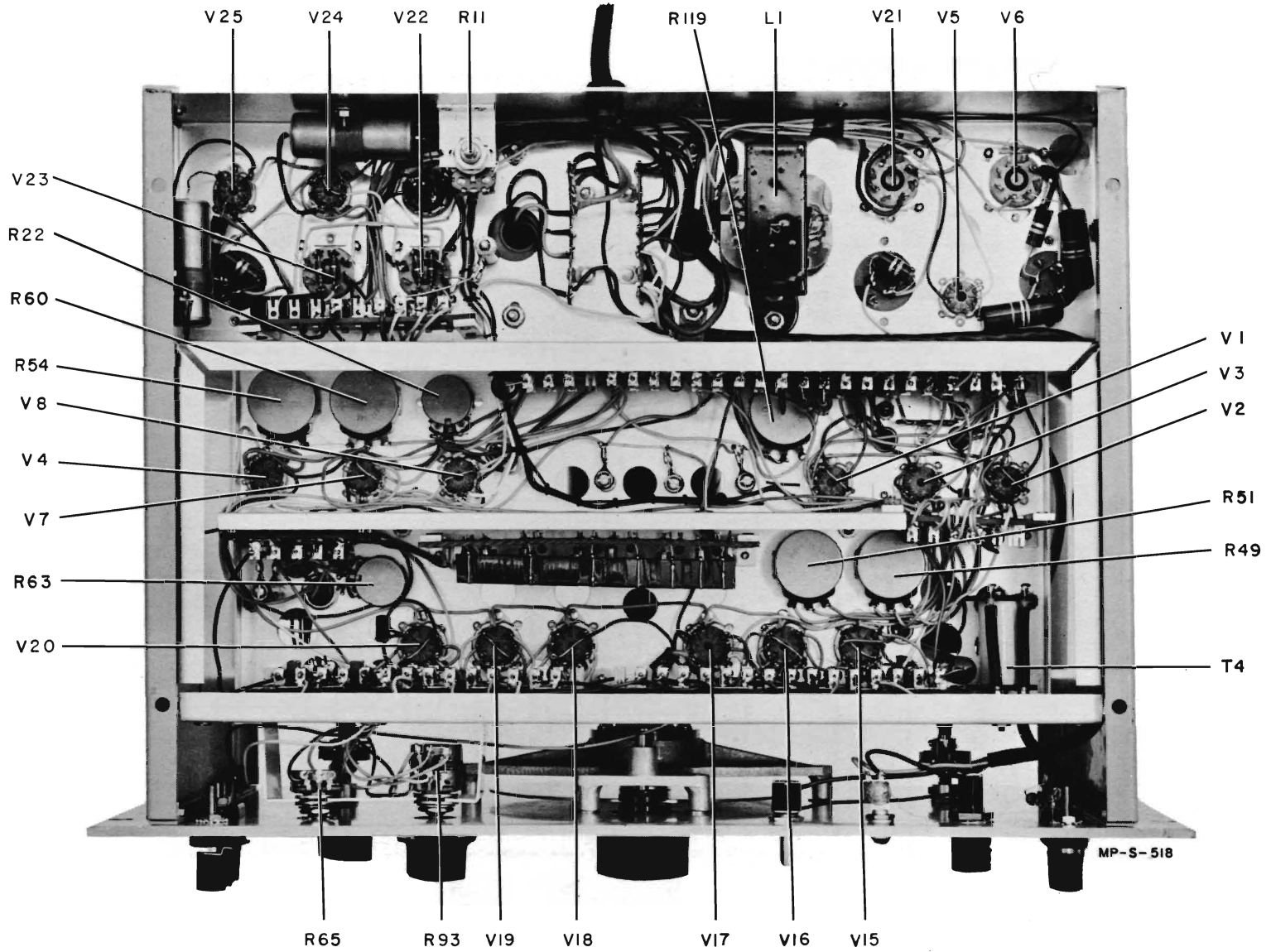
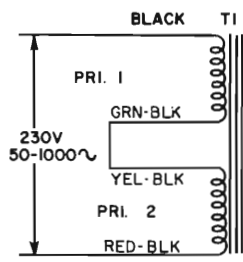
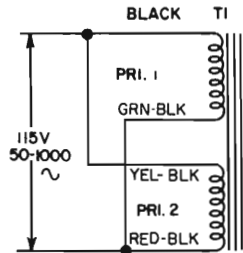
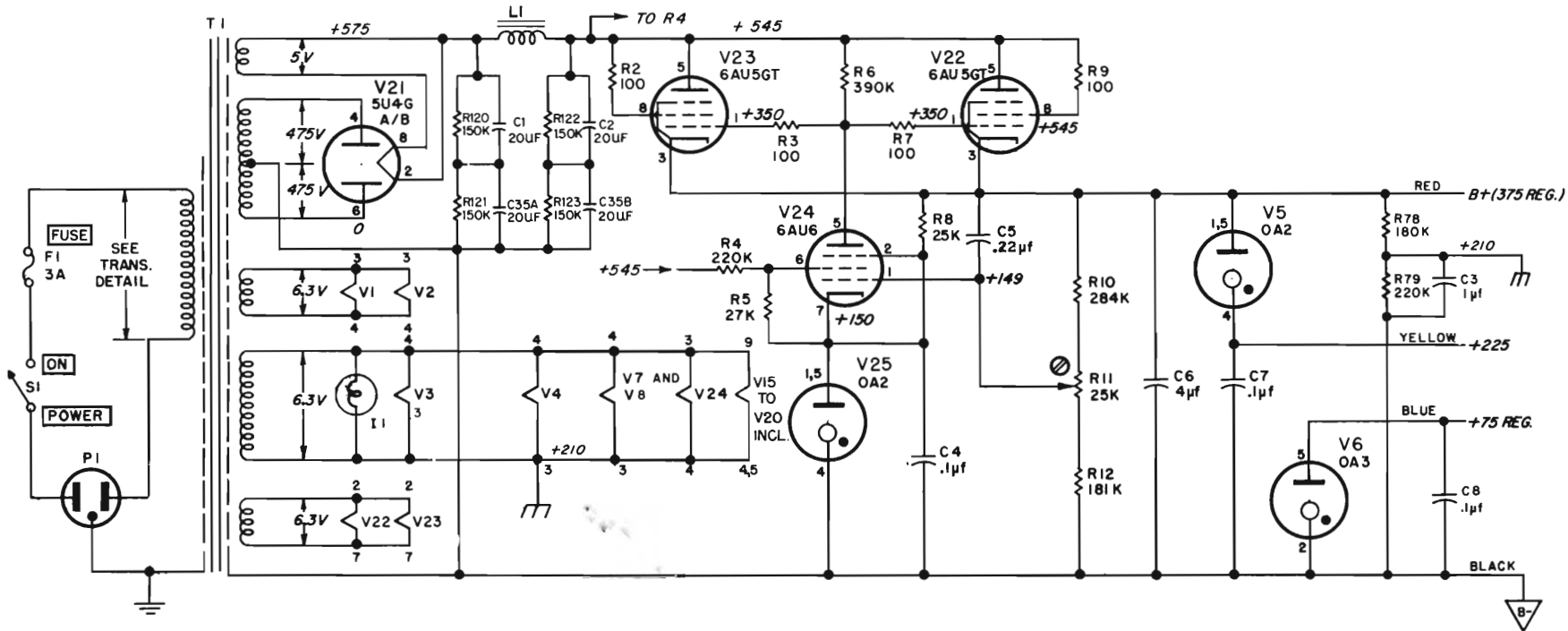

Figure 4-8. Model 202A Bottom View Bottom Plate Removed



TRANSFORMER DETAIL

NOTES: (APPLY TO FUNCTION GENERATOR & AMPLIFIER SECTION AS WELL AS TO POWER SUPPLY SECTION).

CONDITIONS OF DC VOLTAGE MEASUREMENT:

1. 115/230V, 50/1000~ POWER SUPPLY
2. MEASURED BETWEEN THE INDICATED POINTS AND B- WITH A VOLTMETER OF 122MEGOHMS INPUT RESISTANCE. (B- IS ANY BLACK LEAD IN POWER SUPPLY EXCEPT T1 PRIMARY START.)
3. PANEL CONTROLS SET AS FOLLOWS:
 RANGE AT X10.
 FREQUENCY AT 5.
 FUNCTION AT SINE.
 AMPLITUDE AT MAX.

- PANEL CONTROL
- ⊗ SCREWDRIVER ADJ.

* ELECTRICAL VALUE ADJUSTED AT THE FACTORY. AVERAGE VALUE SHOWN. PART MAY BE OMITTED.

- K = 1000 OHMS
- M = 1 MEGOHM
- ✦ MAIN (EXTERNAL) CHASSIS, ISOLATED FROM POWER SUPPLY VOLTAGES.
- ⏏ INTERNAL CHASSIS, ONE POINT CONNECTION TO DIVIDER R78 & R79
- ⚡ (POWER SUPPLY RETURN) IS NOT CONNECTED TO CHASSIS.

CAPACITY IN μUF UNLESS OTHERWISE NOTED.
 202A - PS - T037AB

Figure 4-9. Power Supply

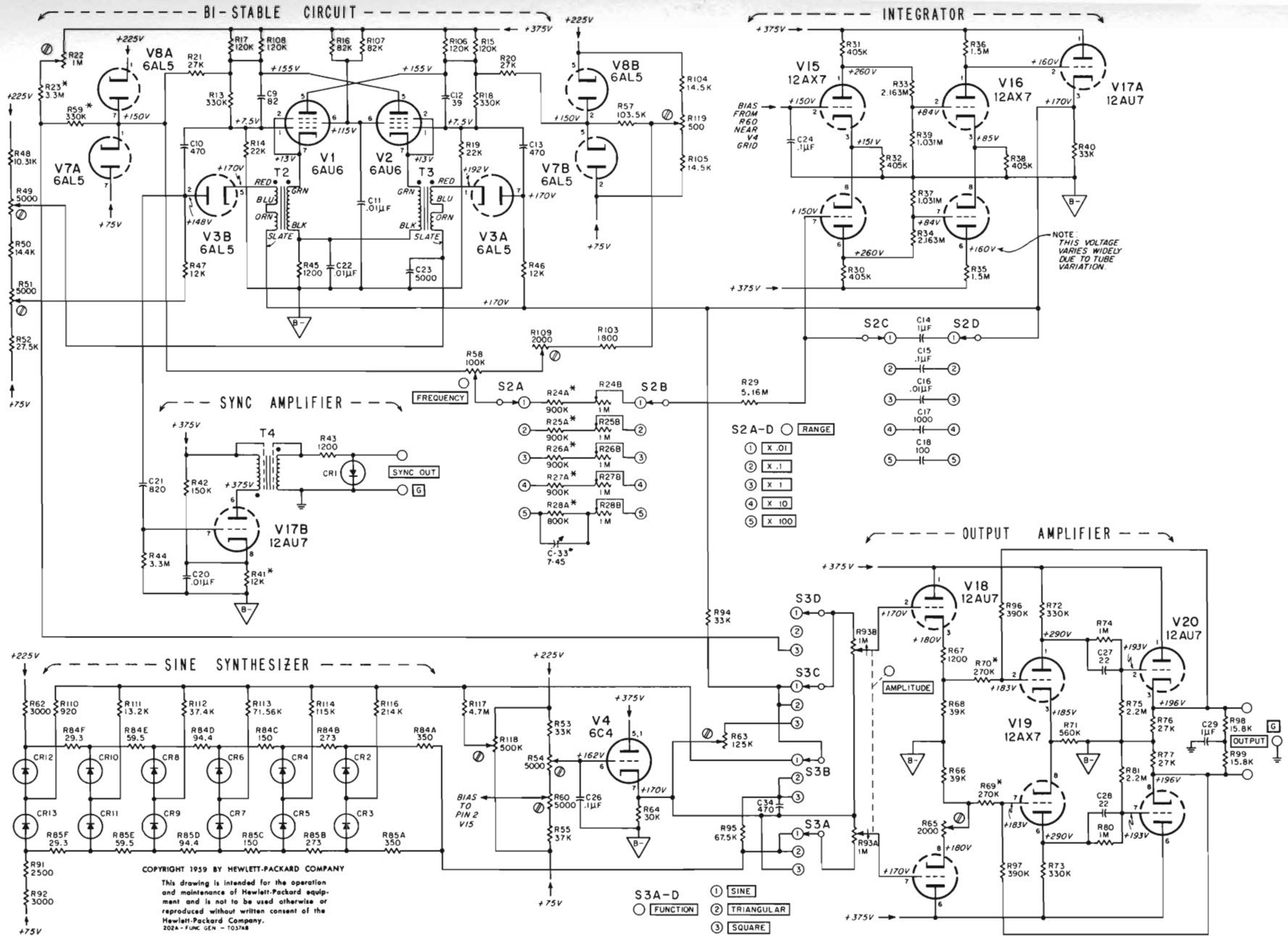

Figure 4-10. Model 202A Function Generator and Amplifier

SECTION V

TABLE OF REPLACEABLE PARTS

NOTE

Standard components have been used in this instrument, whenever possible. Special components may be obtained from your local Hewlett-Packard representative or from the factory.

When ordering parts always include:

1.  Stock Number.
2. Complete description of part including circuit reference.
3. Model number and serial number of instrument.
4. If part is not listed, give complete description, function and location of part.

Corrections to the Table of Replaceable Parts are listed on an Instruction Manual Change sheet at the front of this manual.

RECOMMENDED SPARE PARTS LIST

Column RS in the Table lists the recommended spare parts quantities to maintain one instrument for one year of isolated service. Order complete spare parts kits from the Factory Parts Sales Department. ALWAYS MENTION THE MODEL AND SERIAL NUMBERS OF INSTRUMENTS INVOLVED.

TABLE OF REPLACEABLE PARTS

CIRCUIT REF.	DESCRIPTION, MFR. * & MFR. DESIGNATION	STOCK NO.	TQ	RS		
C1, 2	Capacitor: fixed, electrolytic, 20 μ f, 450 vdcw CC*	0180-0011	2	1		
C3	Capacitor: fixed, paper, 1 μ f \pm 20%, 400 vdcw A*	0160-0016	2	1		
C4	Capacitor: fixed, paper, 0.1 μ f \pm 10%, 400 vdcw CC*	0160-0013	5	2		
C5	Capacitor: fixed, paper, .22 μ f \pm 10%, 400 vdcw CC*	0160-0018	1	1		
C6	Capacitor: fixed, paper 4 μ f \pm 10%, 600 vdcw P*	0160-0077	1	1		
C7, 8	Same as C4					
C9	Capacitor: fixed, mica, 82 pf \pm 10%, 500 vdcw V*	0140-0006	1	1		
C10	Capacitor: fixed, mica, 470 pf \pm 10%, 500 vdcw V*	0140-0027	3	1		
C11	Capacitor: fixed, ceramic .01 μ f, tol. -0% +100%, 1000 vdcw CC*	0150-0012	3	1		
C12	Capacitor: fixed, mica, 39 pf \pm 10%, 500 vdcw V*	0140-0021	1	1		
C13	Same as C10					
C14	Capacitor: fixed, 1 μ f \pm 5%, 400 vdcw AL*	0170-0059	1	1		
C15	Capacitor: fixed, polystyrene, .1 μ f \pm 5%, 300 vdcw J*	0170-0001	1	1		
C16	Capacitor: fixed, polystyrene, .01 μ f \pm 5%, 600 vdcw AL*	0170-0023	1	1		
C17	Capacitor: fixed, silver mica, .001 μ f \pm 5%, 500 vdcw A*	0140-0079	1	1		
C18	Capacitor: fixed, ceramic, 100 pf \pm 5%, 500 vdcw K*	0150-0007	1	1		
C19	This circuit reference not assigned					

* See "List of Manufacturers Code Letters For Replaceable Parts Table".

TQ - Total quantity used in the instrument.

RS - Recommended spares for one year isolated service for one instrument.

TABLE OF REPLACEABLE PARTS

CIRCUIT REF.	DESCRIPTION, MFR. * & MFR. DESIGNATION	Ⓟ STOCK NO.	TQ	RS		
C20	Same as C11					
C21	Capacitor: fixed, mica, 820 pf $\pm 10\%$, 500 vdcw	V* 0140-0010	1	1		
C22	Same as C11					
C23	Capacitor: fixed, ceramic, .005 μ f, 500 vdcw	K* 0150-0014	1	1		
C24	Same as C4					
C25	This circuit reference not assigned					
C26	Same as C4					
C27, 28	Capacitor: fixed, mica, 22 pf $\pm 10\%$, 500 vdcw	Z* 0140-0026	2	1		
C29	Same as C3					
C30, 31, 32	These circuit references not assigned					
C33	Capacitor: variable, ceramic, 7-45 pf, 500 vdcw. Optimum value selected at factory. Average value shown.	L* 0130-0001	1	1		
C34	Same as C10					
C35	Capacitor: fixed, electrolytic, 2 section 20 μ f/sect., 450 vdcw	CC* 0180-0012	1	1		
CR1	Diode, germanium	BU* 1910-0009	1	1		
CR2-13	Diode, silicon	HP* G-29M-45	12	12		
F1	Fuse, cartridge: 3 amp (115V) Fuse, cartridge: 1.6 amp (230V)	T* 2110-0003 E* 2110-0005	1 1	10 0		
II	Lamp, incandescent: 6-8V, 2 pin base GE#12	N* 2140-0012	1	1		
LI	Inductor: 6H at 125 MA, 264 ohms	HP* 9110-0004	1	1		
PI	Power Cable	Elec. Cords Co. 8120-0015	1	1		

* See "List of Manufacturers Code Letters For Replaceable Parts Table".

TQ - Total quantity used in the instrument.

RS - Recommended spares for one year isolated service for one instrument.

TABLE OF REPLACEABLE PARTS

CIRCUIT REF.	DESCRIPTION, MFR. * & MFR. DESIGNATION	Ⓢ STOCK NO.	TQ	RS		
R1	This circuit reference not assigned					
R2, 3	Resistor: fixed, composition, 100 ohms $\pm 10\%$, 1/2 W B*	0687-1011	4	1		
R4	Resistor: fixed, composition, 220,000 ohms $\pm 10\%$, 2 W B*	0693-2241	1	1		
R5	Resistor: fixed, composition, 27,000 ohms $\pm 10\%$, 1 W B*	0690-2731	3	1		
R6	Resistor: fixed, composition, 390,000 ohms $\pm 10\%$, 1 W B*	0690-3941	3	1		
R7	Same as R2					
R8	Resistor: fixed, wirewound, 25,000 ohms $\pm 10\%$, 10 W S*	0816-0009	1	1		
R9	Same as R2					
R10	Resistor: fixed, deposited carbon, 284,000 ohms $\pm 1\%$, 1 W NN*	0730-0083	1	1		
R11	Resistor: variable, composition, linear taper, 25,000 ohms $\pm 20\%$, 1/3 W BO*	2100-0009	1	1		
R12	Resistor: fixed, deposited carbon, 181,000 ohms $\pm 1\%$, 1 W NN*	0730-0077	1	1		
R13	Resistor: fixed, composition, 330,000 ohms $\pm 10\%$, 1 W B*	0690-3341	5	2		
R14	Resistor: fixed, composition, 22,000 ohms $\pm 10\%$, 1 W B*	0690-2231	2	1		
R15	Resistor: fixed, composition, 120,000 ohms $\pm 10\%$, 2 W B*	0693-1241	4	1		
R16	Resistor: fixed, composition, 82,000 ohms $\pm 10\%$, 2 W B*	0693-8231	2	1		
R17	Same as R15					
R18	Same as R13					

* See "List of Manufacturers Code Letters For Replaceable Parts Table".

TQ - Total quantity used in the instrument.

RS - Recommended spares for one year isolated service for one instrument.

TABLE OF REPLACEABLE PARTS

CIRCUIT REF.	DESCRIPTION, MFR. * & MFR. DESIGNATION	Ⓢ STOCK NO.	TQ	RS		
R19	Same as R14					
R20, 21	Same as R5					
R22	Resistor: variable, composition, linear taper, 1 megohm $\pm 30\%$, 1/4 W B*	2100-0074	6	2		
R23	Resistor: fixed, composition, 3.3 megohms $\pm 10\%$, 1 W Optimum value adjusted at factory. Average value shown. B*	0690-3351	1	1		
R24 thru R28	These circuit references not assigned					
R24A thru R27A	Resistor: fixed, deposited carbon, 900,000 ohms $\pm 1\%$ Optimum value selected at factory. Average value shown. NN*	0730-0103	4	1		
R28A	Resistor: fixed, deposited carbon 800,000 ohms $\pm 1\%$ Optimum value selected at factory. Average value shown. NN*	0730-0100	1	1		
R24B thru R28B	Same as R22					
R29	Resistor: fixed, deposited carbon, 5.16 megohms $\pm 1\%$, 1 W NN*	0730-0126	1	1		
R30 thru R32	Resistor: fixed, deposited carbon, 405,000 ohms $\pm 1\%$, 1 W NN*	0730-0088	4	1		
R33, 34	Resistor: fixed, deposited carbon, 2.163 megohms $\pm 1\%$, 1 W NN*	0730-0113	2	1		
R35, 36	Resistor: fixed, composition, 1.5 megohm $\pm 10\%$, 1 W B*	0690-1551	2	1		
R37	Resistor: fixed, deposited carbon, 1.031 megohm $\pm 1\%$, 1 W NN*	0730-0106	2	1		
R38	Same as R31					
R39	Same as R37					
R40	Resistor: fixed, composition, 33,000 ohms $\pm 10\%$, 2 W R*	0693-3331	1	1		
R41	Resistor: fixed, composition, 12,000 ohms $\pm 10\%$, 1/2 W Optimum value selected at factory. Average value shown. B*	0687-1231	1	1		
R42	Resistor: fixed, composition, 150,000 ohms $\pm 10\%$, 2 W B*	0693-1541	5	2		
R43	Resistor: fixed, composition, 1200 ohms $\pm 10\%$, 1 W B*	0690-1221	3	1		

* See "List of Manufacturers Code Letters For Replaceable Parts Table".

TQ - Total quantity used in the instrument.

RS - Recommended spares for one year isolated service for one instrument.

TABLE OF REPLACEABLE PARTS

CIRCUIT REF.	DESCRIPTION, MFR. * & MFR. DESIGNATION	Ⓢ STOCK NO.	TQ	RS		
R44	Resistor: fixed, composition, 3.3 megohms $\pm 10\%$, 1 W B*	0690-3351	1	1		
R45	Same as R43					
R46, 47	Resistor: fixed, composition, 12,000 ohms $\pm 10\%$, 1 W B*	0690-1231	2	1		
R48	Resistor: fixed, deposited carbon, 10.310 ohms $\pm 1\%$, 1 W NN*	0730-0031	1	1		
R49	Resistor: variable, wirewound, linear taper, 5000 ohms $\pm 10\%$, 2 W BO*	2100-0006	4	1		
R50	Resistor: fixed, deposited carbon, 14,400 ohms $\pm 1\%$, 1 W NN*	0730-0034	1	1		
R51	Same as R49					
R52	Resistor: fixed, deposited carbon, 27,500 ohms $\pm 1\%$, 1 W NN*	0730-0044	1	1		
R53	Resistor: fixed, deposited carbon, 33,000 ohms $\pm 1\%$, 1 W NN*	0730-0048	2	1		
R54	Same as R49					
R55	Resistor: fixed, deposited carbon, 37,000 ohms $\pm 1\%$, 1 W NN*	0730-0049	1	1		
R56	This circuit reference not assigned					
R57	Resistor: fixed, deposited carbon, 103,500 ohms $\pm 1\%$, 1 W NN*	0730-0070	1	1		
R58	Resistor: variable, wirewound, 100,000 ohms $\pm 1\%$, 8 W HP*	2100-0244	1	1		
R59	Same as R13 Optimum value selected at factory. Average value shown.					
R60	Same as R49					
R61	This circuit reference not assigned					
R62	Resistor: fixed, wirewound, 3000 ohms $\pm 10\%$, 10 W S*	0816-0002	2	1		

* See "List of Manufacturers Code Letters For Replaceable Parts Table".

TQ - Total quantity used in the instrument.

RS - Recommended spares for one year isolated service for one instrument.

TABLE OF REPLACEABLE PARTS

CIRCUIT REF.	DESCRIPTION, MFR. * & MFR. DESIGNATION	Ⓢ STOCK NO.	TQ	RS		
R63	Resistor: variable, composition, linear taper, 125,000 ohms $\pm 20\%$, 1/4 W BO*	2100-0073	1	1		
R64	Resistor: fixed, wirewound, 30,000 ohms $\pm 5\%$, 10 W R*	0815-0001	1	1		
R65	Resistor: variable, composition, linear taper 2000 ohms $\pm 20\%$, 1/3 W BO*	2100-0153	2	1		
R66	Resistor: fixed, composition, 39,000 ohms $\pm 10\%$, 1 W B*	0690-3931	2	1		
R67	Same as R43					
R68	Same as R66					
R69, 70	Resistor: fixed, composition, 270,000 ohms $\pm 10\%$, 1 W B*	0690-2741	2	1		
R71	Resistor: fixed, composition, 560,000 ohms $\pm 10\%$, 1 W B*	0690-5641	1	1		
R72, 73	Same as R13					
R74	Resistor: fixed, composition, 1 megohm $\pm 10\%$, 1 W B*	0690-1051	2	1		
R75	Resistor: fixed, composition, 2.2 megohms $\pm 10\%$, 1 W B*	0690-2251	2	1		
R76, 77	Resistor: fixed, composition, 27,000 ohms $\pm 10\%$, 2 W B*	0693-2731	2	1		
R78	Resistor: fixed, composition, 180,000 ohms $\pm 10\%$, 1 W B*	0690-1841	1	1		
R79	Resistor: fixed, composition, 220,000 ohms $\pm 10\%$, 1 W B*	0690-2241	1	1		
R80	Same as R74					
R81	Same as R75					
R82	This circuit reference not assigned					

* See "List of Manufacturers Code Letters For Replaceable Parts Table".

TQ - Total quantity used in the instrument.

RS - Recommended spares for one year isolated service for one instrument.

TABLE OF REPLACEABLE PARTS

CIRCUIT REF.	DESCRIPTION, MFR. * & MFR. DESIGNATION	Ⓢ STOCK NO.	TQ	RS		
R83	This circuit reference not assigned					
R84a-f, R85a-f	Resistor: fixed, wirewound HP*	202A-26C	2	1		
R86 thru R90	These circuit references not assigned					
R91	Resistor: fixed, wirewound, 2500 ohms $\pm 10\%$, 10 W S*	0816-0005	1	1		
R92	Same as R62					
R93	Resistor: variable, composition, dual tandem, linear taper, 1 megohm/sect. $\pm 20\%$ BO*	2100-0258	1	1		
R94	Same as R53					
R95	Resistor: fixed, deposited carbon, 67,500 ohms $\pm 1\%$, 1/2 W NN*	0727-0199	1	1		
R96, 97	Same as R6					
R98, 99	Resistor: fixed, deposited carbon, 15,800 ohms $\pm 1\%$, 1 W NN*	0730-0036	2	1		
R100, 101 102	These circuit references not assigned					
R103	Resistor: fixed, composition, 1800 ohms $\pm 10\%$, 1 W B*	0690-1821	1	1		
R104, 105	Resistor: fixed, wirewound, 14,500 ohms, $\pm 1\%$, 3 W AC*	0811-0038	2	1		
R106	Same as R15					
R107	Same as R16					
R108	Same as R15					

* See "List of Manufacturers Code Letters For Replaceable Parts Table".

TQ - Total quantity used in the instrument.

RS - Recommended spares for one year isolated service for one instrument.

TABLE OF REPLACEABLE PARTS

CIRCUIT REF.	DESCRIPTION, MFR. * & MFR. DESIGNATION	Ⓟ STOCK NO.	TQ	RS		
R109	Same as R65					
R110	Resistor: fixed, deposited carbon, 920 ohms $\pm 1\%$, 1/2 W	NN* 0727-0096	1	1		
R111	Resistor: fixed, deposited carbon, 13,200 ohms $\pm 1\%$, 1/2 W	NN* 0727-0165	1	1		
R112	Resistor: fixed, deposited carbon, 37,400 ohms $\pm 1\%$, 1/2 W	NN* 0727-0187	1	1		
R113	Resistor: fixed, deposited carbon, 71,560 ohms $\pm 1\%$, 1/2 W	NN* 0727-0201	1	1		
R114	Resistor: fixed, deposited carbon, 115,000 ohms $\pm 1\%$, 1/2 W	NN* 0727-0213	1	1		
R115	This circuit reference not assigned					
R116	Resistor: fixed, deposited carbon, 214,000 ohms $\pm 1\%$, 1/2 W	NN* 0727-0222	1	1		
R117	Resistor: fixed, composition, 4.7 megohms $\pm 10\%$, 1/2 W	B* 0687-4751	1	1		
R118	Resistor: variable, composition, linear taper, 500,000 ohms, $\pm 20\%$, 1/4 W	B* 2100-0015	1	1		
R119	Resistor: variable, wirewound, linear taper 500 ohms, $\pm 10\%$, 2 W	BO* 2100-0054	1	1		
R120 thru R123	Same as R42		4			
S1	Switch, toggle: SPST	D* 3101-0001	1	1		
S2	Range Switch Assy: (includes C15 thru C18, C33, R24A thru R28A, R29)	HP* 202A-19W	1	1		
S3	Function Switch Assy: (includes C34, R94, R95, R117)	HP* 202A-19B	1	1		
T1	Transformer, power	HP* 9100-0026	1	1		
T2, 3	Transformer, pulse	HP* 9130-0002	2	1		
T4	Transformer, pulse	HP* 202A-60B	1	1		
V1, 2	Tube, electron: 6AU6	ZZ* 1923-0021	3	3		
V3	Tube, electron: 6AL5		3	3		
V4	Tube, electron: 6C4	ZZ* 1921-0005	1	1		
V5	Tube, electron: OA2	ZZ* 1940-0004	2	2		
V6	Tube, electron: OA3	ZZ* 1940-0006	1	1		
V7, 8	Same as V3					

* See "List of Manufacturers Code Letters For Replaceable Parts Table".

TQ - Total quantity used in the instrument.

RS - Recommended spares for one year isolated service for one instrument.

TABLE OF REPLACEABLE PARTS

CIRCUIT REF.	DESCRIPTION, MFR. * & MFR. DESIGNATION	hp STOCK NO.	TQ	RS		
V9 thru V14	These circuit references not assigned					
V15, 16	Tube, electron: 12AX7 ZZ*	1932-0030	3	3		
V17, 18	Tube, electron: 12AU7 ZZ*	1932-0029	3	3		
V19	Same as V15					
V20	Same as V17					
V21	Tube, electron: 5U4GA/B ZZ*	1930-0008	1	1		
V22, 23	Tube, electron: 6AV5GA or 6AU5GT ZZ*	1923-0023 1923-0020	2	2		
V24	Same as V1					
V25	Same as V5					
<u>MISCELLANEOUS</u>						
	Binding Post Assembly: red HP*	AC-10D	3	1		
	Binding Post Assembly: black HP*	AC-10C	1	1		
	Binding Post Insulator: (2 holes) HP*	AC-54A	1	0		
	Binding Post Insulator: (3 holes) HP*	AC-54B	1	0		
	Connector Assembly: (binding post, with ground link) HP*	G-76K	1	1		
	Coupler, flexible: 1/4" to 1/4" shaft HP*	AC-32A	2	1		
	Coupler, metal bellows type HP*	417A-32	1	1		
	Dial, frequency HP*	202A-40A	1	0		
	Escutcheon, dial window HP*	G-99E	1	0		
	Fuseholder T*	1400-0084	1	1		

* See "List of Manufacturers Code Letters For Replaceable Parts Table".

TQ - Total quantity used in the instrument.

RS - Recommended spares for one year isolated service for one instrument.

TABLE OF REPLACEABLE PARTS

CIRCUIT REF.	DESCRIPTION, MFR. * & MFR. DESIGNATION	Ⓢ STOCK NO.	TQ	RS		
	Indicator, dial	HP* 202A-40B	1	0		
	Knob: AMPLITUDE	HP* G-74K	1	0		
	Knob: FREQ.	HP* G-74R	2	0		
	Knob: FUNCTION, RANGE	HP* G-74N	2	0		
	Plug button (R65) United Carr Fast. Corp.	6960-0003	1	0		
	Pilot Light Assembly: jewel	HP* 1450-0020	1	0		
	Pilot Light Assembly: lampholder	HP* 1450-0022	1	0		
	Socket, tube, 9 pin	AE* 1200-0008	6	1		
	Socket, tube, 7 pin	AE* 1200-0009	9	1		
	Socket, tube, octal	AE* 1200-0020	4	1		

* See "List of Manufacturers Code Letters For Replaceable Parts Table".

TQ - Total quantity used in the instrument.

RS - Recommended spares for one year isolated service for one instrument.

LIST OF CODE LETTERS USED IN TABLE OF REPLACEABLE PARTS TO DESIGNATE THE MANUFACTURERS

<u>CODE LETTER</u>	<u>MANUFACTURER</u>	<u>ADDRESS</u>	<u>CODE LETTER</u>	<u>MANUFACTURER</u>	<u>ADDRESS</u>
A	Aerovox Corp.	New Bedford, Mass.	AK	Hammerlund Mfg. Co., Inc.	New York 1, N. Y.
B	Allen-Bradley Co.	Milwaukee 4, Wis.	AL	Industrial Condenser Corp.	Chicago 18, Ill.
C	Amperite Co.	New York, N. Y.	AM	Insuline Corp. of America	Manchester, N. H.
D	Arrow, Hart & Hegeman	Hartford, Conn.	AN	Jennings Radio Mfg. Corp.	San Jose, Calif.
E	Bussman Manufacturing Co.	St. Louis, Mo.	AO	E. F. Johnson Co.	Waseca, Minn.
F	Carborundum Co.	Niagara Falls, N. Y.	AP	Lenz Electric Mfg. Co.	Chicago 47, Ill.
G	Centralab	Milwaukee 1, Wis.	AQ	Micro-Switch	Freeport, Ill.
H	Cinch-Jones Mfg. Co.	Chicago 24, Ill.	AR	Mechanical Industries Prod. Co.	Akron 8, Ohio
HP	Hewlett-Packard Co.	Palo Alto, Calif.	AS	Model Eng. & Mfg., Inc.	Huntington, Ind.
I	Clarostat Mfg. Co.	Dover, N. H.	AT	The Muter Co.	Chicago 5, Ill.
J	Cornell Dubilier Elec. Co.	South Plainfield, N. J.	AU	Ohmite Mfg. Co.	Skokie, Ill.
K	Hi-Q Division of Aerovox	Olean, N. Y.	AV	Resistance Products Co.	Harrisburg, Pa.
L	Erie Resistor Corp.	Erie 6, Pa.	AW	Radio Condenser Co.	Camden 3, N. J.
M	Fed. Telephone & Radio Corp.	Clifton, N. J.	AX	Shallcross Manufacturing Co.	Collingdale, Pa.
N	General Electric Co.	Schenectady 5, N. Y.	AY	Solar Manufacturing Co.	Los Angeles 58, Calif.
O	General Electric Supply Corp.	San Francisco, Calif.	AZ	Sealectro Corp.	New Rochelle, N. Y.
P	Girard-Hopkins	Oakland, Calif.	BA	Spencer Thermostat	Attleboro, Mass.
Q	Industrial Products Co.	Danbury, Conn.	BC	Stevens Manufacturing Co.	Mansfield, Ohio
R	International Resistance Co.	Philadelphia 8, Pa.	BD	Torrington Manufacturing Co.	Van Nuys, Calif.
S	Lectrohm Inc.	Chicago 20, Ill.	BE	Vector Electronic Co.	Los Angeles 65, Calif.
T	Littlefuse Inc.	Des Plaines, Ill.	BF	Weston Electrical Inst. Corp.	Newark 5, N. J.
U	Maguire Industries Inc.	Greenwich, Conn.	BG	Advance Electric & Relay Co.	Burbank, Calif.
V	Micamold Radio Corp.	Brooklyn 37, N. Y.	BH	E. I. DuPont	San Francisco, Calif.
W	Oak Manufacturing Co.	Chicago 10, Ill.	BI	Electronics Tube Corp.	Philadelphia 18, Pa.
X	P. R. Mallory Co., Inc.	Indianapolis, Ind.	BJ	Aircraft Radio Corp.	Boonton, N. J.
Y	Radio Corp. of America	Harrison, N. J.	BK	Allied Control Co., Inc.	New York 21, N. Y.
Z	Sangamo Electric Co.	Marion, Ill.	BL	Augat Brothers, Inc.	Attleboro, Mass.
AA	Sarkes Tarzian	Bloomington, Ind.	BM	Carter Radio Division	Chicago, Ill.
BB	Signal Indicator Co.	Brooklyn 37, N. Y.	BN	CBS Hytron Radio & Electric	Danvers, Mass.
CC	Sprague Electric Co.	North Adams, Mass.	BO	Chicago Telephone Supply	Elkhart, Ind.
DD	Stackpole Carbon Co.	St. Marys, Pa.	BP	Henry L. Crowley Co., Inc.	West Orange, N. J.
EE	Sylvania Electric Products Co.	Warren, Pa.	BQ	Curtiss-Wright Corp.	Carlstadt, N. J.
FF	Western Electric Co.	New York 5, N. Y.	BR	Allen B. DuMont Labs	Clifton, N. J.
GG	Wilkor Products, Inc.	Cleveland, Ohio	BS	Excel Transformer Co.	Oakland, Calif.
HH	Amphenol	Chicago 50, Ill.	BT	General Radio Co.	Cambridge 39, Mass.
II	Dial Light Co. of America	Brooklyn 37, N. Y.	BU	Hughes Aircraft Co.	Culver City, Calif.
JJ	Leecraft Manufacturing Co.	New York, N. Y.	BV	International Rectifier Corp.	El Segundo, Calif.
KK	Switchcraft, Inc.	Chicago 22, Ill.	BW	James Knights Co.	Sandwich, Ill.
LL	Gremar Manufacturing Co.	Wakefield, Mass.	BX	Mueller Electric Co.	Cleveland, Ohio
MM	Carad Corp.	Redwood City, Calif.	BY	Precision Thermometer & Inst. Co.	Philadelphia 30, Pa.
NN	Electra Manufacturing Co.	Kansas City, Mo.	BZ	Radio Essentials Inc.	Mt. Vernon, N. Y.
OO	Acro Manufacturing Co.	Columbus 16, Ohio	CA	Raytheon Manufacturing Co.	Newton, Mass.
PP	Alliance Manufacturing Co.	Alliance, Ohio	CB	Tung-Sol Lamp Works, Inc.	Newark 4, N. J.
QQ	Arco Electronics, Inc.	New York 13, N. Y.	CD	Varian Associates	Palo Alto, Calif.
RR	Astron Corp.	East Newark, N. J.	CE	Victory Engineering Corp.	Union, N. J.
SS	Axel Brothers Inc.	Long Island City, N. Y.	CF	Weckesser Co.	Chicago 30, Ill.
TT	Belden Manufacturing Co.	Chicago 44, Ill.	CG	Wilco Corporation	Indianapolis, Ind.
UU	Bird Electronics Corp.	Cleveland 14, Ohio	CH	Winchester Electronics, Inc.	Santa Monica, Calif.
VV	Barber Colman Co.	Rockford, Ill.	CI	Malco Tool & Die	Los Angeles 42, Calif.
WW	Bud Radio Inc.	Cleveland 3, Ohio	CJ	Oxford Electric Corp.	Chicago 15, Ill.
XX	Allen D. Cardwell Mfg. Co.	Plainville, Conn.	CK	Camloc-Fastener Corp.	Paramus, N. J.
YY	Cinema Engineering Co.	Burbank, Calif.	CL	George K. Garrett	Philadelphia 34, Pa.
ZZ	Any brand tube meeting RETMA standards,		CM	Union Switch & Signal	Swissvale, Pa.
AB	Corning Glass Works	Corning, N. Y.	CN	Radio Receptor	New York 11, N. Y.
AC	Dale Products, Inc.	Columbus, Neb.	CO	Automatic & Precision Mfg. Co.	Yonkers, N. Y.
AD	The Drake Mfg. Co.	Chicago 22, Ill.	CP	Bassick Co.	Bridgeport 2, Conn.
AE	Elco Corp.	Philadelphia 24, Pa.	CQ	Birnbach Radio Co.	New York 13, N. Y.
AF	Hugh H. Eby Co.	Philadelphia 44, Pa.	CR	Fischer Specialties	Cincinnati 6, Ohio
AG	Thomas A. Edison, Inc.	West Orange, N. J.	CS	Telefunken (c/o MVM, Inc.)	New York, N. Y.
AH	Fansteel Metallurgical Corp.	North Chicago, Ill.	CT	Potter-Brumfield Co.	Princeton, Ind.
AI	General Ceramics & Steatite Corp.	Keasbey, N. J.	CU	Cannon Electric Co.	Los Angeles, Calif.
AJ	The Gudeman Co.	Sunnyvale, Calif.	CV	Dynac, Inc.	Palo Alto, Calif.
			CW	Good-All Electric Mfg. Co.	Ogallala, Nebr.

hp MANUAL CHANGES

MODEL 202A

LOW FREQUENCY FUNCTION GENERATOR

Manual Serial Prefixed: 037-
Manual Printed: 1/61

To adapt this manual to instruments with other serial prefixes check for errata below, and make changes shown in tables.

Instrument Serial Prefix	Make Manual Changes	Instrument Serial Prefix	Make Manual Changes
All	1		

CHANGE 1

Table of Replaceable Parts,
CR1: Change $\text{\textcircled{P}}$ Stock No. to 1910-0009.

Under MISCELLANEOUS:

Fuseholder: Change $\text{\textcircled{P}}$ Stock No. to 1400-0084.

Figure 4-7, Power Supply schematic diagram,
The wire color-code of T1 primary is as follows:

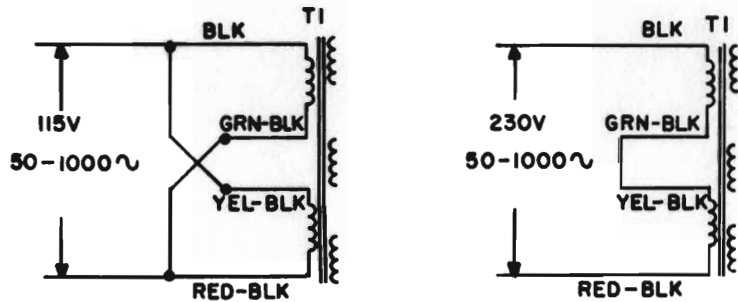

Table of Replaceable Parts,

CR2 thru CR13: Change to diode, 1N459A; $\text{\textcircled{P}}$ Stock No. 1901-0033.

ERRATA:

Table of Replaceable Parts,

C11: Change description to: "Capacitor, fixed, ceramic, 0.01 uf $\pm 20\%$, 1000 vdcw.

C15: Change description to: "Capacitor, fixed, polystyrene, 0.1 uf $\pm 5\%$, 400 vdcw.

R48: Change value to 10.31K ohms.

3/15/62

1/8/62

